

**SKS EXTREME**

# High-feed milling tools with double side inserts which achieve ultimate high-feed machining

**Feature 1**

**Economical double-side insert (with 6 cutting edges)**



**Feature 2**

**Due to dovetail-shaped binding face, movement of inserts which occur by cutting force is prevented only single screw clamping**

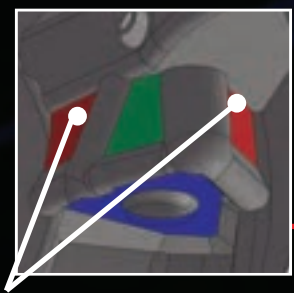

**Dovetail-shaped**



**Feature 3**

**Application**

ISO	P					M					K				H		
	P01	P10	P20	P30	P40	M01	M10	M20	M30	M40	K01	K10	K20	K30	H01	H10	H20
Applicable range			JC8050					JC8050									
		JC8118									JC8118					JC8118	
			JC7560						JC7560								

Adopted 3 insert grades:

PVD coated grade "JC7560" improved fracture toughness & heat impact resistance.

PVD coated grade "JC8118" achieved longer tool life for mold steel, high hardened die steel less than 50HRC & cast iron.

PVD coated grade "JC8050", that adopted carbide substrate with improved fracture toughness & coating layer can be widely applied for carbon steel, mold steel, & stainless steel.



M3 size screw for firm clamping of inserts

MaxAp=1.5mm

W=4.8

## EXSKS-05 type

By adopting multi blade specification with small diameter, high-feed machining is possible.

### WNMU050320ZER-PM



grade : JC8050  
JC8118

Optimal breaker for mold steel & High hardened steel less than 50HRC

Coner radius for programming	Remains	Over cut
R2	0.59	0
R2.5	0.5	0
R3	0.41	0.13



MaxAp=2mm

W=8.1

## EXSKS-07type

Adopted specifications which achieved both insert strength and sharpness. Stable high-feed machining is possible.

### WNMU070620ZER-PM



grade : JC8050  
JC8118

Optimal breaker for mold steel & High hardened steel less than 50HRC

Coner radius for programming	Remains	Over cut
R3	0.80	0
R3.5	0.73	0.06
R4	0.66	0.21



Lined up holders of big diameter. High-feed machining with bigger depth of cut is possible by adopting high-rigid inserts with larger thickness.

MaxAp=3mm (2mm)

W=8.2

PM insert PL insert

## EXSKS-09type

### WNMU090828ZER-PL

grade: JC8050 / JC8118

Suitable for machining shapes such as pocket milling with ap = 0.6 mm to ap = 1.2 mm. The composite shape of the straight and radius cutting edges reduces fluctuations in cutting resistance during corner machining, realizing stable machining and extending tool life.

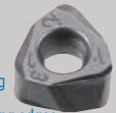

### WNMU090720ZER-PM

grade : JC8050/JC8118/JC7560

Suitable for face milling of ap=1.4mm or more and shape machining such as pocket machining.



Coner radius for programming	Remains	Over cut
R3	1.41	0
R3.5	1.3	0
R4	1.19	0.025

**SKS EXTREME** **EXSKS/MEX Type**

- EXSKS-05 Type
- Facemill Type

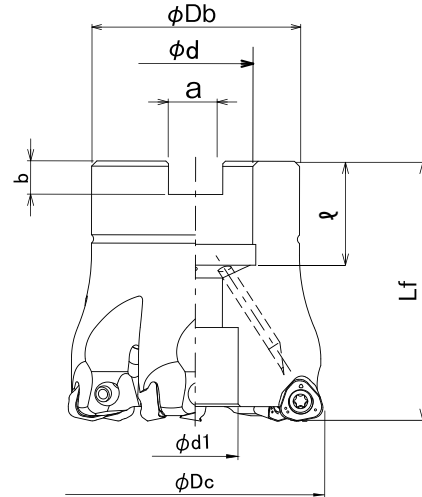
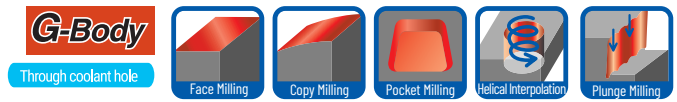

Cat.No.	Stock	No. of inserts	Dimensions (mm)								Arbor set bolt	Weight (kg)	Inserts 
			φDc	Lf	φDb	φd	φd1	a	b	φ			
EXSKS-5040R-05-16	●	5	40	45	35	16	13.5	8.4	5.8	19	M8	0.25	WNMU050320ZER-PM
EXSKS-7050R-05-22	●	7	50	50	40	22	16.5	10.4	6.3	20	M10	0.39	
EXSKS-7052R-05-22	●	7	52	50	40	22	16.5	10.4	6.3	20	M10	0.41	
EXSKS-8063R-05-22	□	8	63	50	48	22	17	10.4	6.3	20	M10	0.65	

■ Modular head type

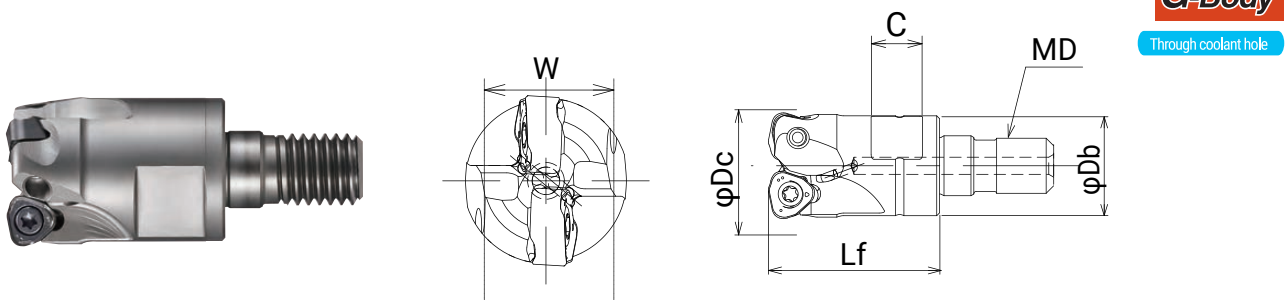

Cat.No.	Stock	No. of inserts	Dimensions (mm)						Inserts 
			φDc	Lf	φDb	MD	C	W	
MEX-2020-05-M10	●	2	20	30	18	M10	9	14	WNMU050320ZER-PM
MEX-2021-05-M10	□	2	21	30	18	M10	9	14	
MEX-3025-05-M12	●	3	25	35	23	M12	11	19	
MEX-3026-05-M12	□	3	26	35	23	M12	11	19	
MEX-3028-05-M12	□	3	28	28	23	M12	11	19	
MEX-4030-05-M16	□	4	30	43	27	M16	12	22	
MEX-4032-05-M16	●	4	32	43	29	M16	12	22	
MEX-4033-05-M16	□	4	33	43	29	M16	12	22	
MEX-4035-05-M16	●	4	35	43	29	M16	12	22	
MEX-5040-05-M16	●	5	40	43	32	M16	14	26	

**SKS EXTREME** **EXSKS/MEX Type**

■ Endmill Shank Type

Through coolant hole

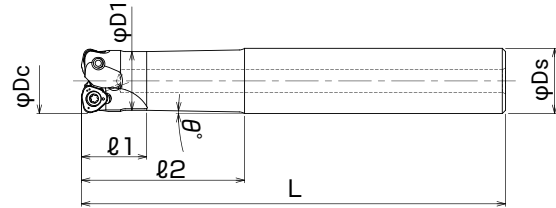

Cat.No.	Stock	No. of inserts	Dimensions (mm)							Inserts
			φDc	ℓ1	ℓ2	L	φd1	φDs	θ°	
EXSKS-2020-05-50-S20	●	2	20	20	18	130	18	20	1	WNMU050320ZER- PM
EXSKS-2020-05-80-S20	□	2	20	20	18	160	18	20	0.5	
EXSKS-2021-05-50-S20	□	2	21	20	23	130	18	20	1	
EXSKS-2021-05-80-S20	□	2	21	20	23	160	18	20	0.5	
EXSKS-3025-05-60-S25	●	3	25	25	23	140	23	25	1	
EXSKS-3025-05-100-S25	□	3	25	25	27	180	23	25	0.5	
EXSKS-3026-05-60-S25	□	3	26	25	29	140	23	25	1	
EXSKS-3026-05-100-S25	□	3	26	25	29	180	23	25	0.5	
EXSKS-4032-05-70-S32	●	4	32	30	29	150	29	32	1.5	
EXSKS-4032-05-120-S32	□	4	32	30	32	200	29	32	0.5	

Screw	Torque(N.m)	Wrench
TSW-307H	2.1	A-10

■ Insert

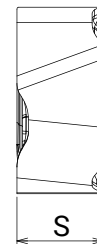
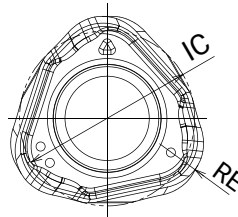

Cat.No.	Tolerance	PVD coated		Dimensions (mm)		
		JC8118	JC8050	RE	IC	S
WNMU050320ZER-PM	M	●	●	2	7.7	3.9

**GRADE MARKING**

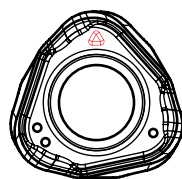

JC8050

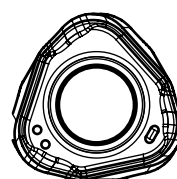

JC8118

**SKS EXTREME** **EXSKS/MEX Type**

- EXSKS-07 Type
- Facemill Type

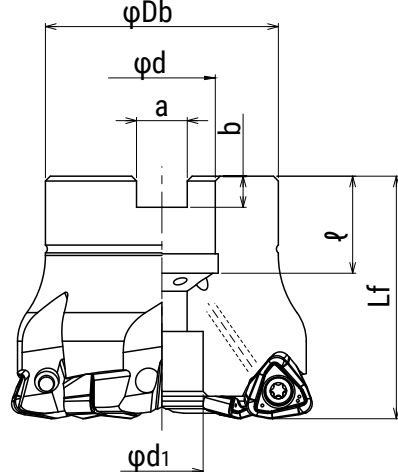
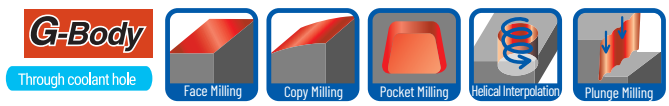

Cat.No.	Stock	No. of inserts	Dimensions (mm)								Arbor set bolt	Weight (kg)	Inserts 
			phi Dc	Lf	phi Db	phi d	phi d1	a	b	phi			
EXSKS-5050R-07-22	●	5	50	50	40	22	16.5	10.4	6.3	20	M10	0.38	WNMU070620ZER-PM
EXSKS-5052R-07-22	●	5	52	50	40	22	16.5	10.4	6.3	20	M10	0.40	
EXSKS-6063R-07-22	●	6	63	50	48	22	17	10.4	6.3	20	M10	0.64	
EXSKS-7080R-07-27	●	7	80	55	65	27	20	12.4	7	22	M12X1.75X35★	1.23	

■ Modular head type

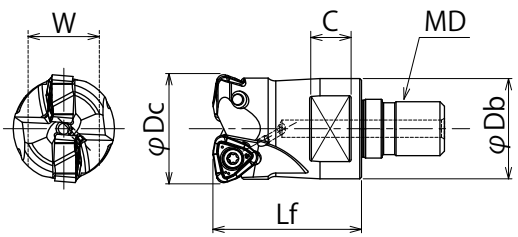

Cat.No.	Stock	No. of inserts	Dimensions (mm)						Inserts 
			phi Dc	Lf	phi Db	MD	C	W	
MEX-2032-07-M16	●	2	32	43	29	M16	12	22	WNMU070620ZER-PM
MEX-3035-07-M16	●	3	35	43	29	M16	12	22	
MEX-4040-07-M16	●	4	40	43	32	M16	14	26	
MEX-4042-07-M16	●	4	42	43	32	M16	14	26	

**SKS EXTREME** **EXSKS/MEX Type**

■ Endmill Shank Type

Through coolant hole

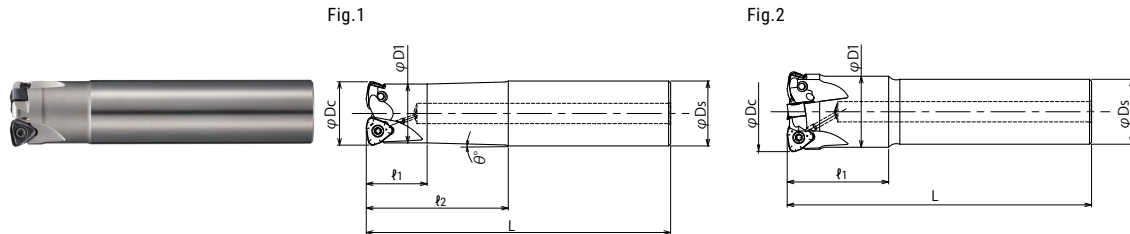

Cat.No.	Stock	No. of inserts	Dimensions (mm)								Inserts
			$\varphi D_c$	$\ell_1$	$\ell_2$	L	$\varphi d_1$	$\varphi D_s$	$\theta^\circ$	Fig.	
EXSKS-2032-07-70-S32	<input type="checkbox"/>	2	32	30	70	150	29	20	32	1	WNMU070620ZER-PM
EXSKS-2032-07-120-S32	<input type="checkbox"/>	2	32	30	120	200	29	20	32	1	
EXSKS-3035-07-40-S32	<input type="checkbox"/>	3	35	40	-	150	31	20	32	2	
EXSKS-3035-07-40L-S32	<input type="checkbox"/>	3	35	40	-	200	31	20	32	2	
EXSKS-4040-07-50-S32	<input type="checkbox"/>	4	40	50	-	150	35	25	32	2	
EXSKS-4040-07-50L-S32	<input type="checkbox"/>	4	40	50	-	200	35	25	32	2	

■ Insert

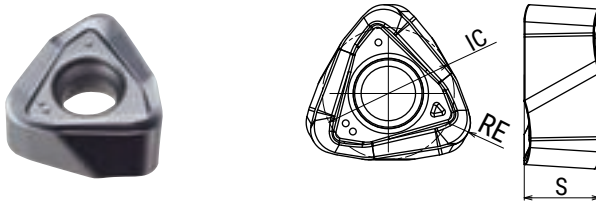

Screw	Torque(N.m)	Wrench
TSW-410H	3.5	A-15

Cat.No.	Tolerance	PVD coated		Dimensions (mm)		
		JC8118	JC8050	RE	IC	S
WNMU070620ZER-PM	M	●	●	2	11.2	6.4

**GRADE MARKING**

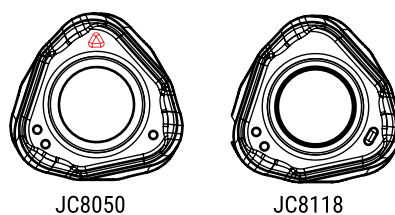

**SKS EXTREME** **EXSKS/MEX Type**

- EXSKS-09 Type
- Facemill Type

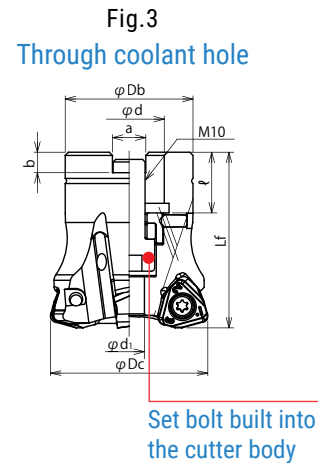
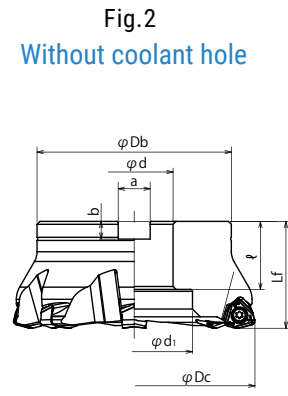
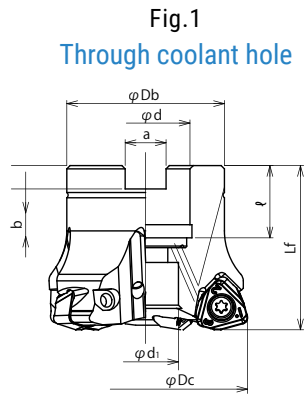

Cat.No.	Stock	No. of inserts	Dimensions (mm)								Arbor set bolt	Weight (kg)	Fig.	Inserts 
			φDc	Lf	φDb	φd	φd1	a	b	ℓ				
EXSKS-3050R-22	□	3	50	55	40	22	9.6	10.4	6.3	19	M10×1.5×25	0.4	3	WNMU090720ZER-PM WNMU090828ZER-PL
EXSKS-4050R-22	●	4	50	55	40	22	9.6	10.4	6.3	19	M10×1.5×25	0.3	3	
EXSKS-4052R-22	●	4	52	50	40	22	17	10.4	6.3	20	M10	0.4	1	
EXSKS-4063R-22	□	4	63	50	48	22	17	10.4	6.3	20	M10	0.5	1	
EXSKS-5063R-22	●	5	63	50	48	22	17	10.4	6.3	20	M10	0.5	1	
EXSKS-5063R-27	●	5	63	50	48	27	20	12.4	7	22	M12×1.75×30	0.5	1	
EXSKS-5066R-27	●	5	66	50	48	27	20	12.4	7	22	M12×1.75×30	0.5	1	
EXSKS-6080R-27	●	6	80	55	65	27	37	12.4	7	22	M12×1.75×40	0.9	1	
EXSKS-7100R-32	●	7	100	70	85	32	26	14.4	8	32	M16×2×45	1.9	1	
EXSKS-8125R-40	●	8	125	70	100	40	32	16.4	9	35	M20×2.5×45	3.9	1	
EXSKS-9160R-40	●	9	160	55	100	40	85	16.4	9	35	M20	3.9	2	

**SKS EXTREME** **EXSKS/MEX Type**

■ **Insert**

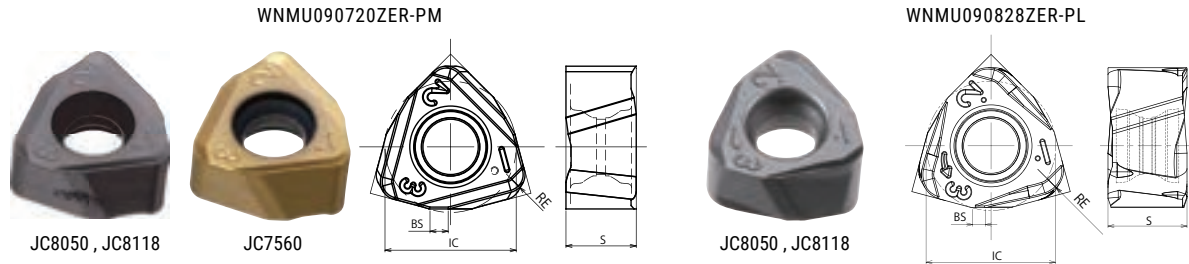

Cat.No.	Tolerance	PVD coated			Dimensions (mm)			
		JC8118	JC8050	JC7560	IC	S	BS	RE
WNMU090720ZER-PM	M	●	●	●	14	7.66	1.94	2
WNMU090828ZER-PL	M	●	●		13.91	8.66	1.37	2.8

Note: When using PL inserts, tool dia. will be smaller than PM insert.  
 In case dia.  $\phi 100$  holder, tool dia. is 0.06mm smaller.  
 In case dia.  $\phi 125$  holder, tool dia. is 0.11mm smaller.  
 In case dia.  $\phi 160$  holder, tool dia. is 0.15mm smaller

Screw	Torque(N.m)	Wrench
CSW-513H	5.5	A-20

**GRADE MARKING**

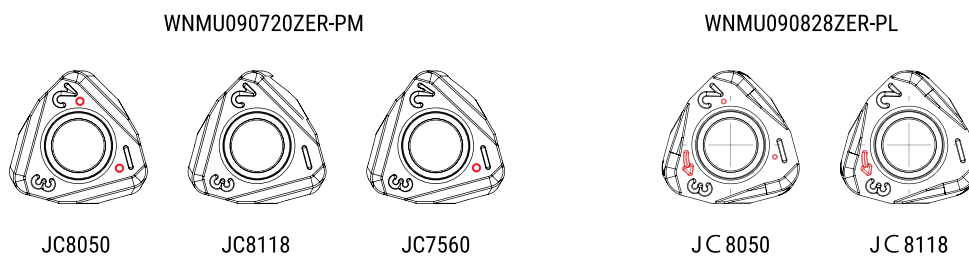

**SKS EXTREME** **EXSKS/MEX Type**

■ EXSKS-05 type : Definition of corner shape for programming

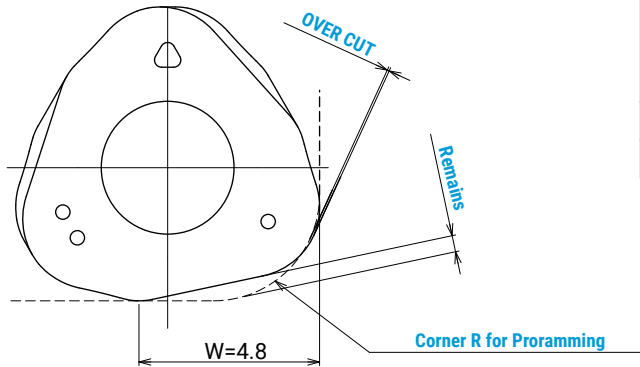

Corner radius for programming	Remains	Over cut
R2.0	0.59	0
R2.5 (Std.)	0.5	0
R3.0	0.41	0.13

(mm)

**Attention for profile milling**

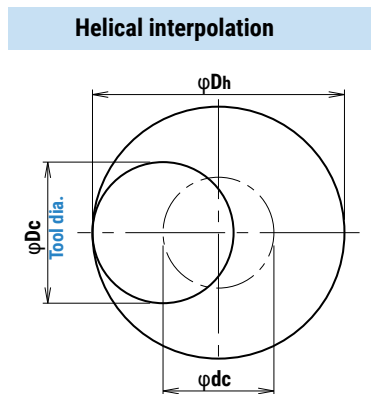
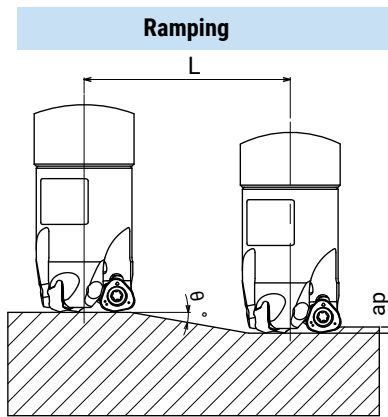

● Calculation of tool pass dia.

$$\varphi Dc = \varphi Dh - \varphi Dc$$

Tool pass dia.    Bore dia.    Tool dia.

- Depth of cut per one circuit should not exceed max. depth of cut ap.
- Down cutting is recommended, so tool pass rotation should be counterclockwise.
- To obtain a flat bottom surface when helical milling, it requires to remove "the uncut part" in the center of the work material at a final pass.

- In case of ramping and helical interpolation, apply 70% or less feed speed from standard cutting condition table.
- In case of drilling, apply 50% or less Z axis feed speed from standard cutting condition table.
- Long consecutive chips may come out in case of drilling, confirm the safe condition sufficiently.

Cat. No.	Tool dia. (mm)	EFF. Cutting dia. (mm)	Max. depth of cut (mm) ap	Ramping		Helical interpolation			Max. drilling depth Z (mm)
				Max. ramping angle θ°	Total cutting length at Max ap	Min. bore dia. Dh min (mm)	Max. bore dia. Dh min (mm)	Dh min (mm)	
EXSKS-*020/MEX-*020	20	10	1.5	2.8	31	28	36	31	0.4
EXSKS-*021/MEX-*021	21	11	1.5	2.6	34	30	38	33	0.4
EXSKS-*025/MEX-*025	25	15	1.5	1.8	48	38	46	41	0.4
EXSKS-*026/MEX-*026	26	16	1.5	1.7	51	40	48	43	0.4
EXSKS-*028/MEX-*028	28	18	1.5	1.5	58	44	52	47	0.4
MEX-*030	30	20	1.5	1.3	67	48	56	51	0.4
EXSKS-*032/MEX-*032	32	22	1.5	1.2	72	52	60	55	0.4
MEX-*033	33	23	1.5	1.1	79	54	62	57	0.4
MEX-*035	35	25	1.5	1	86	58	66	61	0.4
EXSKS-*040/MEX-*040	40	30	1.5	0.8	108	68	76	71	0.4
EXSKS-*050	50	40	1.5	0.6	144	88	96	91	0.4
EXSKS-*052	52	42	1.5	0.6	144	92	100	95	0.4
EXSKS-*063	63	53	1.5	0.5	172	114	122	117	0.4

**SKS EXTREME** **EXSKS/MEX Type**

■ EXSKS-07 type : Definition of corner shape for programming

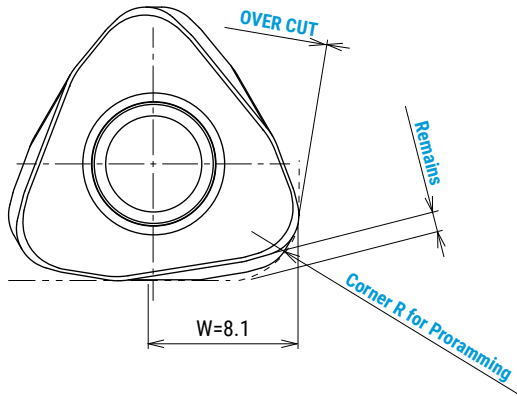

Corner radius for programming	Remains	Over cut
R3.0 (Std.)	0.8	0
R3.5	0.73	0.06
R4.0	0.66	0.21

(mm)

Attention for profile milling

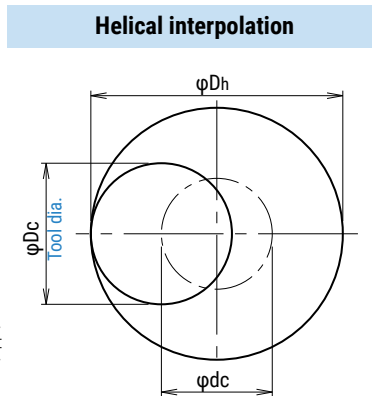
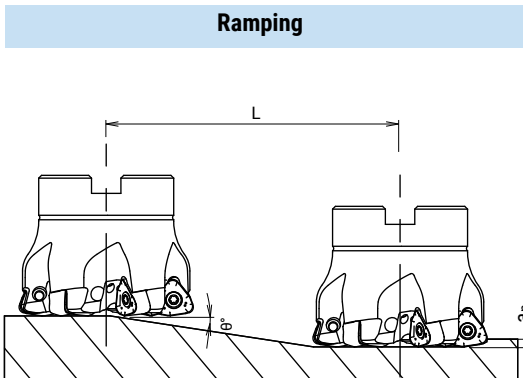

● Calculation of tool pass dia.

$$\varphi_{dc} = \varphi_{Dh} - \varphi_{Dc}$$

Tool pass dia.      Bore dia.      Tool dia.

- Depth of cut per one circuit should not exceed max. depth of cut ap.
- Down cutting is recommended, so tool pass rotation should be counterclockwise.
- To obtain a flat bottom surface when helical milling, it requires to remove "the uncut part" in the center of the work material at a final pass.

- In case of ramping and helical interpolation, apply 70% or less feed speed from standard cutting condition table.
- In case of drilling, apply 50% or less Z axis feed speed from standard cutting condition table.
- Long consecutive chips may come out in case of drilling, confirm the safe condition sufficiently.

Cat. No.	Tool dia. (mm)	EFF. Cutting dia. (mm)	Max. depth of cut (mm) ap	Ramping		Helical interpolation			Max. drilling depth Z (mm)
				Max. ramping angle θ°	Total cutting length at Max ap	Min. bore dia. Dh min (mm)	Max. bore dia. Dh min (mm)	Dh min (mm)	
EXSKS-*032/MEX-*032	32	15	2	2.2	53	41	60	48	0.5
EXSKS-*035/MEX-*035	35	18	2	2.1	55	47	66	54	0.5
EXSKS-*040/MEX-*040	40	23	2	2	58	57	76	64	0.5
MEX-*042	42	25	2	1.8	64	61	80	68	0.5
EXSKS-*050	50	33	2	1.5	77	77	96	84	0.5
EXSKS-*052	52	35	2	1.2	96	81	100	88	0.5
EXSKS-*063	63	46	2	1	115	103	122	110	0.5
EXSKS-*080	80	63	2	0.8	144	137	156	144	0.5

**SKS EXTREME**

**EXSKS/MEX Type**

■ EXSKS-09 type : Definition of corner shape for programming

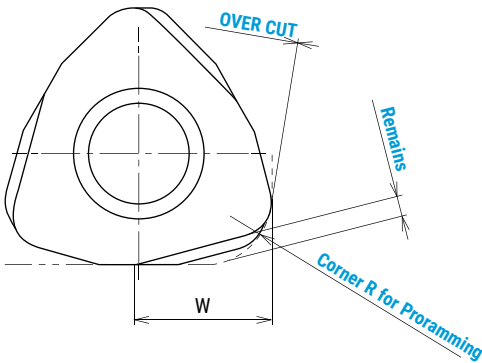

Insert	W	Corner radius for programming	Remains	Over cut
WNMU090720ZER-PM	8.2	R3.0	1.41	0
		R3.5	1.30	0
		R4.0	1.19	0.025
Insert	W	Corner radius for programming	Remains	Over cut
WNMU090828ZER-PL	8.4	R3.0	1.18	0
		R3.5	1.06	0
		R4.0	0.95	0.010

**Attention for profile milling**

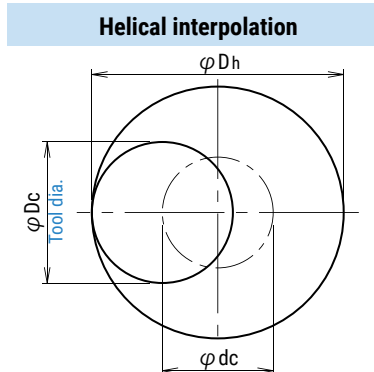
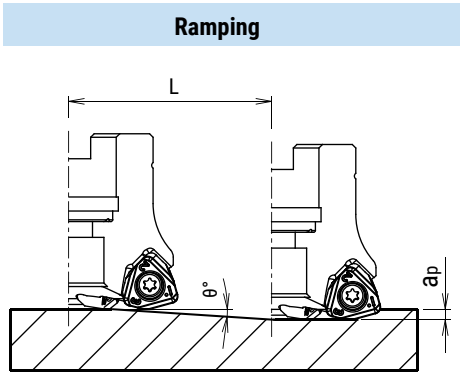

● Calculation of tool pass dia.

$$\varphi_{dc} = \varphi_{Dh} - \varphi_{Dc}$$

Tool pass dia.    Bore dia.    Tool dia.

- Depth of cut per one circuit should not exceed max. depth of cut ap.
- Down cutting is recommended, so tool pass rotation should be counterclockwise.
- To obtain a flat bottom surface when helical milling, it requires to remove "the uncut part" in the center of the work material at a final pass.

- In case of ramping and helical interpolation, apply 70% or less feed speed from standard cutting condition table.
- In case of drilling, apply 50% or less Z axis feed speed from standard cutting condition table.
- Long consecutive chips may come out in case of drilling, confirm the safe condition sufficiently.

**WNMU090720ZER-PM**

Cat. No.	Tool dia. (mm)	EFF. Cutting dia. (mm)	Max. depth of cut (mm) ap	Ramping		Helical interpolation			Max. drilling depth Z (mm)
				Max. ramping angle θ°	Total cutting length at Max ap	Min. bore dia. Dh min (mm)	Max. bore dia. Dh min (mm)	Dh min (mm)	
EXSKS-*050	50	33	3	2.5	69	73	96	81	1.1
EXSKS-*052	52	35	3	2.4	72	77	100	85	1.2
EXSKS-*063	63	46	3	1.8	96	99	122	107	1.2
EXSKS-*066	66	49	3	1.7	102	105	128	113	1.2
EXSKS-*080	80	63	3	1.3	133	133	156	141	1.3
EXSKS-*100	100	83	3	1	172	173	196	181	1.3
EXSKS-*125	125	108	3	0.9	191	223	246	231	1.3
EXSKS-*160	160	143	3	0.7	246	293	316	301	1.7

**WNMU090828ZER-PL**

Cat. No.	Tool dia. (mm)	EFF. Cutting dia. (mm)	Max. depth of cut (mm) ap	Ramping		Helical interpolation			Max. drilling depth Z (mm)
				Max. ramping angle θ°	Total cutting length at Max ap	Min. bore dia. Dh min (mm)	Max. bore dia. Dh min (mm)	Dh min (mm)	
EXSKS-*050	50	33	2	2.3	50	74	96	82	1
EXSKS-*052	52	35	2	2.2	53	78	100	86	1
EXSKS-*063	63	46	2	1.8	64	100	122	108	1.2
EXSKS-*066	66	49	2	1.7	68	106	128	114	1.2
EXSKS-*080	80	63	2	1.3	89	134	156	142	1.3
EXSKS-*100	99.94	83	2	1	115	174	195	182	1.3
EXSKS-*125	124.89	108	2	0.9	128	224	245	232	1.4
EXSKS-*160	159.85	142	2	0.7	164	294	315	302	1.6

**SKS EXTREME****EXSKS/MEX Type**

■ Recommended cutting conditions

● MEX05 Modular Head type + MSN Shank

Material	Grade	Tool dia.(mm)									
		20/21					25/26/28				
		2N					3N				
		ℓ (mm)	a <sub>p</sub> (mm)	a <sub>e</sub> (mm)	n (min <sup>-1</sup> )	V <sub>f</sub> (mm/min)	ℓ (mm)	a <sub>p</sub> (mm)	a <sub>e</sub> (mm)	n (min <sup>-1</sup> )	V <sub>f</sub> (mm/min)
Carbon steel (S50C, S55C) below 250HB	JC8050 (JC8118)	~60	0.8	~9	3,180	7,630	~75	0.8	~14	2,550	9,180
		100	0.7	~9	3,180	7,000	125	0.7	~14	2,550	8,420
		140	0.5	~9	2,860	5,720	175	0.5	~14	2,290	6,870
Tool & die steel (SKD61, SKD11) below 255HB	JC8050 (JC8118)	~60	0.8	~9	2,860	6,860	~75	0.8	~14	2,290	8,240
		100	0.7	~9	2,860	6,290	125	0.7	~14	2,290	7,560
		140	0.5	~9	2,550	5,100	175	0.5	~14	2,040	6,120
Mold steel (HPM7, PX5, P20) 30-36 HRC	JC8118 (JC8050)	~60	0.8	~9	2,860	6,860	~75	0.8	~14	2,290	8,240
		100	0.7	~9	2,860	6,290	125	0.7	~14	2,290	7,560
		140	0.5	~9	2,550	5,100	175	0.5	~14	2,040	6,120
Mold steel (NAK80, HPM1, P21) 38-43HRC	JC8118 (JC8050)	~60	0.6	~9	2,070	4,140	~75	0.6	~14	1,660	4,980
		100	0.6	~9	2,070	3,310	125	0.6	~14	1,660	3,980
		140	0.5	~9	1,750	2,800	175	0.5	~14	1,400	3,360
Hardened die steel (SKD61, DAC, DHA) 42-52HRC	JC8118	~60	0.6	~9	1,590	2,540	~75	0.6	~14	1,270	3,050
		100	0.6	~9	1,590	2,540	125	0.6	~14	1,270	3,050
		140	0.5	~9	1,430	1,720	175	0.5	~14	1,150	2,070
Grey cast iron (FC250) 160-260HB	JC8118 (JC8050)	~60	1	~9	3,180	8,900	~75	1	~14	2,550	10,710
		100	0.8	~9	3,180	7,630	125	0.8	~14	2,550	9,180
		140	0.6	~9	2,860	5,720	175	0.6	~14	2,290	6,870
Nodular cast iron (FCD700) 170-300HB	JC8118 (JC8050)	~60	1	~9	2,860	6,860	~75	1	~14	2,290	8,240
		100	0.8	~9	2,860	6,290	125	0.8	~14	2,290	7,560
		140	0.6	~9	2,550	5,100	175	0.6	~14	2,040	6,120
Austenitic stainless steel (SUS304, 316, 317) 17Cr	JC8050	~60	0.6	~9	2,390	4,780	~75	0.6	~14	1,910	5,730
		100	0.5	~9	2,390	4,300	125	0.5	~14	1,910	5,160
		140	0.5	~9	2,070	3,310	175	0.5	~14	1,660	3,980
Ferritic & martensitic stainless steel (SUS403 420J2, 430) 13Cr	JC8118 (JC8050)	~60	0.8	~9	2,710	6,500	~75	0.8	~14	2,160	7,780
		100	0.7	~9	2,710	6,500	125	0.7	~14	2,160	7,780
		140	0.5	~9	2,390	4,780	175	0.5	~14	1,910	5,730

## Note

1. Please adjust cutting conditions according to machine rigidity or work rigidity. (the above table is guide for cutting on a #50 BT machine.)
2. In case of chatter occurring, recommended to reduce a<sub>p</sub> or rpm and keep feed per tooth.
3. a<sub>p</sub> should be reduced when using on low rigidity machine.
4. Use air blow.

**SKS EXTREME** **EXSKS/MEX Type**

- Recommended cutting conditions
- MEX05 Modular Head type + MSN Shank

Material	Grade	Tool dia.(mm)									
		30/32/33/35					40				
		4N					5N				
		ℓ (mm)	ap (mm)	ae (mm)	n (min <sup>-1</sup> )	Vf (mm/min)	ℓ (mm)	ap (mm)	ae (mm)	n (min <sup>-1</sup> )	Vf (mm/min)
Carbon steel (S50C, S55C) below 250HB	JC8050 (JC8118)	~90	0.8	~20	1,990	9,550	~120	0.8	~28	1,430	8,580
		150	0.7	~20	1,990	8,760	200	0.7	~28	1,430	7,870
		210	0.5	~20	1,790	7,160	280	0.5	~28	1,270	6,350
Tool & die steel (SKD61, SKD11) below 255HB	JC8050 (JC8118)	~90	0.8	~20	1,790	8,590	~120	0.8	~28	1,270	7,620
		150	0.7	~20	1,790	7,880	200	0.7	~28	1,270	6,990
		210	0.5	~20	1,590	6,360	280	0.5	~28	1,110	5,550
Mold steel (HPM7, PX5, P20) 30-36 HRC	JC8118 (JC8050)	~90	0.8	~20	1,790	8,590	~120	0.8	~28	1,270	7,620
		150	0.7	~20	1,790	7,880	200	0.7	~28	1,270	6,990
		210	0.5	~20	1,590	6,360	280	0.5	~28	1,110	5,550
Mold steel (NAK80, HPM1, P21) 38-43HRC	JC8118 (JC8050)	~90	0.6	~20	1,290	5,160	~120	0.6	~28	880	4,400
		150	0.6	~20	1,290	4,130	200	0.6	~28	880	3,520
		210	0.5	~20	1,090	3,490	280	0.5	~28	720	2,880
Hardened die steel (SKD61, DAC, DHA) 42-52HRC	JC8118	~90	0.6	~20	990	3,170	~120	0.6	~28	720	2,880
		150	0.6	~20	990	3,170	200	0.6	~28	720	2,880
		210	0.5	~20	900	2,160	280	0.5	~28	560	1,680
Grey cast iron (FC250) 160-260HB	JC8118 (JC8050)	~90	1	~20	1,990	11,140	~120	1	~28	1,430	10,010
		150	0.8	~20	1,990	9,550	200	0.8	~28	1,430	8,580
		210	0.6	~20	1,790	7,160	280	0.6	~28	1,270	6,350
Nodular cast iron (FCD700) 170-300HB	JC8118 (JC8050)	~90	1	~20	1,790	8,590	~120	1	~28	1,270	7,620
		150	0.8	~20	1,790	7,880	200	0.8	~28	1,270	6,990
		210	0.6	~20	1,590	6,360	280	0.6	~28	1,110	5,550
Austenitic stainless steel (SUS304, 316, 317) 17Cr	JC8050	~90	0.6	~20	1,490	5,960	~120	0.6	~28	1,030	5,150
		150	0.5	~20	1,490	5,360	200	0.5	~28	1,030	4,640
		210	0.5	~20	1,290	4,130	280	0.5	~28	880	3,520
Ferritic & martensitic stainless steel (SUS403 420J2, 430) 13Cr	JC8118 (JC8050)	~90	0.8	~20	1,690	8,110	~120	0.8	~28	1,190	7,140
		150	0.7	~20	1,690	8,110	200	0.7	~28	1,190	7,140
		210	0.5	~20	1,490	5,960	280	0.5	~28	1,030	5,150

Note

1. Please adjust cutting conditions according to machine rigidity or work rigidity. (the above table is guide for cutting on a #50 BT machine.)
2. In case of chatter occurring, recommended to reduce ap or rpm and keep feed per tooth.
3. ap should be reduced when using on low rigidity machine.
4. Use air blow.

**SKS EXTREME****EXSKS/MEX Type**

## ■ Recommended cutting conditions

## ● EXSKS05 Endmill type

Material	Grade	Tool dia.(mm)									
		20/21					25/26				
		2N					3N				
		ℓ (mm)	a <sub>p</sub> (mm)	a <sub>e</sub> (mm)	n (min <sup>-1</sup> )	V <sub>f</sub> (mm/min)	ℓ (mm)	a <sub>p</sub> (mm)	a <sub>e</sub> (mm)	n (min <sup>-1</sup> )	V <sub>f</sub> (mm/min)
Carbon steel (S50C, S55C) below 250HB	JC8050 (JC8118)	~60	0.7	~9	3,180	7,630	~70	0.7	~14	2,550	9,180
		60~100	0.6	~9	3,180	7,000	70~120	0.6	~14	2,550	8,420
		-	-	-	-	-	-	-	-	-	-
Tool & die steel (SKD61, SKD11) below 255HB	JC8050 (JC8118)	~60	0.7	~9	2,860	6,860	~70	0.7	~14	2,290	8,240
		60~100	0.6	~9	2,860	6,290	70~120	0.6	~14	2,290	7,560
		-	-	-	-	-	-	-	-	-	-
Mold steel (HPM7, PX5, P20) 30-36 HRC	JC8118 (JC8050)	~60	0.6	~9	2,860	6,860	~70	0.6	~14	2,290	8,240
		60~100	0.5	~9	2,860	6,290	70~120	0.5	~14	2,290	7,560
		-	-	-	-	-	-	-	-	-	-
Mold steel (NAK80, HPM1, P21) 38-43HRC	JC8118 (JC8050)	~60	0.5	~9	2,070	4,140	~70	0.5	~14	1,660	4,980
		60~100	0.4	~9	2,070	3,310	70~120	0.4	~14	1,660	3,980
		-	-	-	-	-	-	-	-	-	-
Hardened die steel (SKD61, DAC, DHA) 42-52HRC	JC8118	~60	0.5	~9	1,590	2,540	~70	0.5	~14	1,270	3,050
		60~100	0.4	~9	1,590	2,540	70~120	0.4	~14	1,270	3,050
		-	-	-	-	-	-	-	-	-	-
Grey cast iron (FC250) 160-260HB	JC8118 (JC8050)	~60	0.8	~9	3,180	8,900	~70	0.8	~14	2,550	10,710
		60~100	0.7	~9	3,180	7,630	70~120	0.7	~14	2,550	9,180
		-	-	-	-	-	-	-	-	-	-
Nodular cast iron (FCD700) 170-300HB	JC8118 (JC8050)	~60	0.8	~9	2,860	6,860	~70	0.8	~14	2,290	8,240
		60~100	0.7	~9	2,860	6,290	70~120	0.7	~14	2,290	7,560
		-	-	-	-	-	-	-	-	-	-
Austenitic stainless steel (SUS304, 316, 317) 17Cr	JC8050	~60	0.6	~9	2,390	4,780	~70	0.6	~14	1,910	5,730
		60~100	0.5	~9	2,390	4,300	70~120	0.5	~14	1,910	5,160
		-	-	-	-	-	-	-	-	-	-
Ferritic & martensitic stainless steel (SUS403 420J2, 430) 13Cr	JC8118 (JC8050)	~60	0.7	~9	2,710	6,500	~70	0.7	~14	2,160	7,780
		60~100	0.6	~9	2,710	6,500	70~120	0.6	~14	2,160	7,780
		-	-	-	-	-	-	-	-	-	-

## Note

1. Please adjust cutting conditions according to machine rigidity or work rigidity. (the above table is guide for cutting on a #50 BT machine.)
2. In case of chatter occurring, recommended to reduce a<sub>p</sub> or rpm and keep feed per tooth.
3. a<sub>p</sub> should be reduced when using on low rigidity machine.
4. Use air blow.

**SKS EXTREME****EXSKS/MEX Type**

## ■ Recommended cutting conditions

## ● EXSKS05 Endmill type

Material	Grade	Tool dia.(mm)				
		32				
		4N				
		ℓ (mm)	ap (mm)	ae (mm)	n (min <sup>-1</sup> )	Vf (mm/min)
Carbon steel (S50C, S55C) below 250HB	JC8050 (JC8118)	~200	0.7	~20	1,990	9,550
		90~140	0.6	~20	1,990	8,760
		-	-	-	-	-
Tool & die steel (SKD61, SKD11) below 255HB	JC8050 (JC8118)	~200	0.7	~20	1,790	8,590
		90~140	0.6	~20	1,790	7,880
		-	-	-	-	-
Mold steel (HPM7, PX5, P20) 30-36 HRC	JC8118 (JC8050)	~200	0.6	~20	1,790	8,590
		90~140	0.5	~20	1,790	7,880
		-	-	-	-	-
Mold steel (NAK80, HPM1, P21) 38-43HRC	JC8118 (JC8050)	~200	0.5	~20	1,290	5,160
		90~140	0.4	~20	1,290	4,130
		-	-	-	-	-
Hardened die steel (SKD61, DAC, DHA) 42-52HRC	JC8118	~200	0.5	~20	990	3,170
		90~140	0.4	~20	990	3,170
		-	-	-	-	-
Grey cast iron (FC250) 160-260HB	JC8118 (JC8050)	~200	0.8	~20	1,990	11,140
		90~140	0.7	~20	1,990	9,550
		-	-	-	-	-
Nodular cast iron (FCD700) 170-300HB	JC8118 (JC8050)	~200	0.8	~20	1,790	8,590
		90~140	0.7	~20	1,790	7,880
		-	-	-	-	-
Austenitic stainless steel (SUS304, 316, 317) 17Cr	JC8050	~200	0.6	~20	1,490	5,960
		90~140	0.5	~20	1,490	5,360
		-	-	-	-	-
Ferritic & martensitic stainless steel (SUS403 420J2, 430) 13Cr	JC8118 (JC8050)	~200	0.7	~20	1,690	8,110
		90~140	0.6	~20	1,690	8,110
		-	-	-	-	-

## Note

1. Please adjust cutting conditions according to machine rigidity or work rigidity.
2. In case of chatter occurring, recommended to reduce ap or rpm and keep feed per tooth.
3. ap should be reduced when using on low rigidity machine.
4. Use air blow.

**SKS EXTREME****EXSKS/MEX Type**

■ Recommended cutting conditions

● EXSKS05 Facemill type

Material	Grade	Tool dia.(mm)									
		40					50/52				
		5N					7N				
		ℓ (mm)	a <sub>p</sub> (mm)	a <sub>e</sub> (mm)	n (min <sup>-1</sup> )	V <sub>f</sub> (mm/min)	ℓ (mm)	a <sub>p</sub> (mm)	a <sub>e</sub> (mm)	n (min <sup>-1</sup> )	V <sub>f</sub> (mm/min)
Carbon steel (S50C, S55C) below 250HB	JC8050 (JC8118)	~150	1	~28	1,270	7,620	~150	1	~38	1,020	8,570
		200	0.8	~28	1,270	6,990	200	0.8	~38	1,020	7,850
		250	0.6	~28	1,110	5,550	250	0.6	~38	890	6,230
		300	-	-	-	-	300	0.5	~38	830	4,650
		350	-	-	-	-	350	-	-	-	-
Tool & die steel (SKD61, SKD11) below 255HB	JC8050 (JC8118)	~150	1	~28	1,190	7,140	~150	1	~38	950	7,980
		200	0.8	~28	1,190	6,550	200	0.8	~38	950	7,320
		250	0.6	~28	1,030	5,150	250	0.6	~38	830	5,810
		300	-	-	-	-	300	0.5	~38	760	4,260
		350	-	-	-	-	350	-	-	-	-
Mold steel (HPM7, PX5, P20) 30-36 HRC	JC8118 (JC8050)	~150	1	~28	1,190	7,140	~150	1	~38	950	7,980
		200	0.8	~28	1,190	6,550	200	0.8	~38	950	7,320
		250	0.6	~28	1,030	5,150	250	0.6	~38	830	5,810
		300	-	-	-	-	300	0.5	~38	760	4,260
		350	-	-	-	-	350	-	-	-	-
Mold steel (NAK80, HPM1, P21) 38-43HRC	JC8118 (JC8050)	~150	0.8	~28	880	4,400	~150	0.8	~38	700	4,900
		200	0.6	~28	880	3,520	200	0.6	~38	700	3,920
		250	0.5	~28	720	2,880	250	0.5	~38	570	3,190
		300	-	-	-	-	300	0.4	~38	510	2,860
		350	-	-	-	-	350	-	-	-	-
Hardened die steel (SKD61, DAC, DHA) 42-52HRC	JC8118	~150	0.7	~28	720	2,880	~150	0.7	~38	570	3,190
		200	0.6	~28	720	2,880	200	0.6	~38	570	3,190
		250	0.5	~28	560	1,680	250	0.5	~38	450	1,890
		300	-	-	-	-	300	-	-	-	-
		350	-	-	-	-	350	-	-	-	-
Grey cast iron (FC250) 160-260HB	JC8118 (JC8050)	~150	1	~28	1,430	10,010	~150	1	~38	1,150	11,270
		200	0.8	~28	1,430	8,580	200	0.8	~38	1,150	9,660
		250	0.6	~28	1,270	6,350	250	0.6	~38	1,020	7,140
		300	-	-	-	-	300	0.5	~38	890	6,230
		350	-	-	-	-	350	-	-	-	-
Nodular cast iron (FCD700) 170-300HB	JC8118 (JC8050)	~150	1	~28	1,270	7,620	~150	1	~38	1,020	8,570
		200	0.8	~28	1,270	6,990	200	0.8	~38	1,020	7,850
		250	0.6	~28	1,110	5,550	250	0.6	~38	890	6,230
		300	-	-	-	-	300	0.5	~38	760	4,790
		350	-	-	-	-	350	-	-	-	-
Austenitic stainless steel (SUS304, 316, 317) 17Cr	JC8050	~150	0.8	~28	1,030	5,150	~150	0.8	~38	830	5,810
		200	0.6	~28	1,030	4,640	200	0.6	~38	830	5,230
		250	0.5	~28	880	3,520	250	0.5	~38	700	3,920
		300	-	-	-	-	300	0.4	~38	640	3,580
		350	-	-	-	-	350	-	-	-	-
Ferritic & martensitic stainless steel (SUS403 420J2, 430) 13Cr	JC8118 (JC8050)	~150	1	~28	1,190	7,140	~150	1	~38	950	7,980
		200	0.8	~28	1,190	7,140	200	0.8	~38	950	7,980
		250	0.6	~28	1,030	5,150	250	0.6	~38	830	5,810
		300	-	-	-	-	300	0.5	~38	-	-
		350	-	-	-	-	350	-	-	-	-

Note

1. Please adjust cutting conditions according to machine rigidity or work rigidity. (the above table is guide for cutting on a #50 BT machine.)
2. In case of chatter occurring, recommended to reduce a<sub>p</sub> or rpm and keep feed per tooth.
3. a<sub>p</sub> should be reduced when using on low rigidity machine.
4. Use air blow.

**SKS EXTREME****EXSKS/MEX Type**

## ■ Recommended cutting conditions

## ● EXSKS05 Facemill type

Material	Grade	Tool dia.(mm)				
		63				
		8N				
		$\ell$ (mm)	$a_p$ (mm)	$a_e$ (mm)	$n$ (min <sup>-1</sup> )	$V_f$ (mm/min)
Carbon steel (S50C, S55C) below 250HB	JC8050 (JC8118)	~150	1	~46	810	6,800
		200	0.8	~46	810	6,240
		250	0.6	~46	710	4,970
		300	0.5	~46	660	3,700
		350	0.4	~46	610	3,420
Tool & die steel (SKD61, SKD11) below 255HB	JC8050 (JC8118)	~150	1	~46	760	6,380
		200	0.8	~46	760	5,850
		250	0.6	~46	660	4,620
		300	0.5	~46	610	3,420
		350	0.4	~46	560	3,140
Mold steel (HPM7, PX5, P20) 30-36 HRC	JC8118 (JC8050)	~150	1	~46	760	6,380
		200	0.8	~46	760	5,850
		250	0.6	~46	660	4,620
		300	0.5	~46	610	3,420
		350	0.4	~46	560	3,140
Mold steel (NAK80, HPM1, P21) 38-43HRC	JC8118 (JC8050)	~150	0.8	~46	560	3,920
		200	0.6	~46	560	3,140
		250	0.5	~46	450	2,520
		300	0.4	~46	400	2,240
		350	-	-	-	-
Hardened die steel (SKD61, DAC, DHA) 42-52HRC	JC8118	~150	0.7	~46	450	2,520
		200	0.6	~46	450	2,520
		250	0.5	~46	350	1,470
		300	-	-	-	-
		350	-	-	-	-
Grey cast iron (FC250) 160-260HB	JC8118 (JC8050)	~150	1	~46	910	8,920
		200	0.8	~46	910	7,640
		250	0.6	~46	810	5,670
		300	0.5	~46	710	4,970
		350	0.5	~46	660	4,160
Nodular cast iron (FCD700) 170-300HB	JC8118 (JC8050)	~150	1	~46	810	6,800
		200	0.8	~46	810	6,240
		250	0.6	~46	710	4,970
		300	0.5	~46	610	3,840
		350	0.5	~46	560	3,140
Austenitic stainless steel (SUS304, 316, 317) 17Cr	JC8050	~150	0.8	~46	660	4,620
		200	0.6	~46	660	4,160
		250	0.5	~46	560	3,140
		300	0.4	~46	510	2,860
		350	0.4	~46	450	2,520
Ferritic & martensitic stainless steel (SUS403 420J2, 430) 13Cr	JC8118 (JC8050)	~150	1	~46	760	6,380
		200	0.8	~46	760	6,380
		250	0.6	~46	660	4,620
		300	0.5	~46	560	3,920
		350	0.5	~46	510	3,570

## Note

1. Please adjust cutting conditions according to machine rigidity or work rigidity. (the above table is guide for cutting on a #50 BT machine.)
2. In case of chatter occurring, recommended to reduce  $a_p$  or rpm and keep feed per tooth.
3.  $a_p$  should be reduced when using on low rigidity machine.
4. Use air blow.

**SKS EXTREME****EXSKS/MEX Type**

## ■ Recommended cutting conditions

## ● MEX07 Modular Head type + MSN Shank

Material	Grade	Tool dia.(mm)									
		32					35				
		2N					3N				
		ℓ (mm)	a <sub>p</sub> (mm)	a <sub>e</sub> (mm)	n (min <sup>-1</sup> )	V <sub>f</sub> (mm/min)	ℓ (mm)	a <sub>p</sub> (mm)	a <sub>e</sub> (mm)	n (min <sup>-1</sup> )	V <sub>f</sub> (mm/min)
Carbon steel (S50C, S55C) below 250HB	JC8050	~100	1	~14	1,990	5,970	~100	1	~18	1,820	8,190
		150	0.8	~14	1,990	5,570	150	0.8	~18	1,820	7,640
		210	0.6	~14	1,790	4,650	210	0.6	~18	1,640	6,400
Tool & die steel (SKD61, SKD11) below 255HB	JC8050	~100	1	~14	1,790	5,370	~100	1	~18	1,640	7,380
		150	0.8	~14	1,790	5,010	150	0.8	~18	1,640	6,890
		210	0.6	~14	1,590	4,130	210	0.6	~18	1,460	5,690
Mold steel (HPM7, PX5, P20) 30-36 HRC	JC8118	~100	1	~14	1,790	5,370	~100	1	~18	1,640	7,380
		150	0.8	~14	1,790	5,010	150	0.8	~18	1,640	6,890
		210	0.6	~14	1,590	4,130	210	0.6	~18	1,460	5,690
Mold steel (NAK80, HPM1, P21) 38-43HRC	JC8118	~100	0.8	~14	1,290	3,100	~100	0.8	~18	1,180	4,250
		150	0.6	~14	1,290	2,840	150	0.6	~18	1,180	3,890
		210	0.4	~14	1,090	2,180	210	0.4	~18	1,000	3,000
Hardened die steel (SKD61, DAC, DHA) 42-52HRC	JC8118	~100	0.8	~14	990	1,980	~100	0.8	~18	910	2,730
		150	0.6	~14	990	1,780	150	0.6	~18	910	2,460
		210	0.4	~14	800	1,280	210	0.4	~18	730	1,750
Grey cast iron (FC250) 160-260HB	JC8118	~100	1.5	~14	1,990	5,970	~100	1.5	~18	1,820	8,190
		150	1.2	~14	1,990	5,970	150	1.2	~18	1,820	8,190
		210	0.8	~14	1,790	5,010	210	0.8	~18	1,640	6,890
Nodular cast iron (FCD700) 170-300HB	JC8118	~100	1	~14	1,690	5,070	~100	1	~18	1,550	6,980
		150	0.8	~14	1,690	4,730	150	0.8	~18	1,550	6,510
		210	0.6	~14	1,490	3,870	210	0.6	~18	1,360	5,300
Austenitic stainless steel (SUS304, 316, 317) 17Cr	JC8050	~100	0.8	~14	1,490	3,580	~100	0.8	~18	1,360	4,900
		150	0.6	~14	1,490	3,280	150	0.6	~18	1,360	4,490
		210	0.4	~14	1,290	2,580	210	0.4	~18	1,180	3,540
Ferritic & martensitic stainless steel (SUS403 420J2, 430) 13Cr	JC8118	~100	1	~14	1,690	4,060	~100	1	~18	1,550	5,580
		150	0.8	~14	1,690	3,720	150	0.8	~18	1,550	5,120
		210	0.6	~14	1,490	2,980	210	0.6	~18	1,360	4,080

## Note

1. Please adjust cutting conditions according to machine rigidity or work rigidity. (the above table is guide for cutting on a #50 BT machine.)
2. In case of chatter occurring, recommended to reduce a<sub>p</sub> or rpm and keep feed per tooth.
3. a<sub>p</sub> should be reduced when using on low rigidity machine.
4. Use air blow.

**SKS EXTREME****EXSKS/MEX Type**

- Recommended cutting conditions  
 ● MEX07 Modular Head type + MSN Shank

Material	Grade	Tool dia.(mm)				
		40/42				
		4N				
		ℓ (mm)	a <sub>p</sub> (mm)	a <sub>e</sub> (mm)	n (min <sup>-1</sup> )	V <sub>f</sub> (mm/min)
Carbon steel (S50C, S55C) below 250HB	JC8050	~100	1	~23	1,430	8,580
		150	0.8	~23	1,430	8,010
		210	0.6	~23	1,270	6,600
Tool & die steel (SKD61, SKD11) below 255HB	JC8050	~100	1	~23	1,270	7,620
		150	0.8	~23	1,270	7,110
		210	0.6	~23	1,110	5,770
Mold steel (HPM7, PX5, P20) 30-36 HRC	JC8118	~100	1	~23	1,270	7,620
		150	0.8	~23	1,270	7,110
		210	0.6	~23	1,110	5,770
Mold steel (NAK80, HPM1, P21) 38-43HRC	JC8118	~100	0.8	~23	880	4,220
		150	0.6	~23	880	3,870
		210	0.4	~23	720	2,880
Hardened die steel (SKD61, DAC, DHA) 42-52HRC	JC8118	~100	0.8	~23	720	2,880
		150	0.6	~23	720	2,590
		210	0.4	~23	560	1,790
Grey cast iron (FC250) 160-260HB	JC8118	~100	1.5	~23	1,430	8,580
		150	1.2	~23	1,430	8,580
		210	0.8	~23	1,270	7,110
Nodular cast iron (FCD700) 170-300HB	JC8118	~100	1	~23	1,190	7,140
		150	0.8	~23	1,190	6,660
		210	0.6	~23	1,030	5,360
Austenitic stainless steel (SUS304, 316, 317) 17Cr	JC8050	~100	0.8	~23	1,030	4,940
		150	0.6	~23	1,030	4,530
		210	0.4	~23	880	3,520
Ferritic & martensitic stainless steel (SUS403 420J2, 430) 13Cr	JC8118	~100	1	~23	1,190	5,710
		150	0.8	~23	1,190	5,240
		210	0.6	~23	1,030	4,120

## Note

1. Please adjust cutting conditions according to machine rigidity or work rigidity. (the above table is guide for cutting on a #50 BT machine.)
2. In case of chatter occurring, recommended to reduce a<sub>p</sub> or rpm and keep feed per tooth.
3. a<sub>p</sub> should be reduced when using on low rigidity machine.
4. Use air blow.

**SKS EXTREME****EXSKS/MEX Type**

- Recommended cutting conditions
- EXSKS07 Endmill shank type

Material	Grade	Tool dia.(mm)									
		32					35				
		2N					3N				
		ℓ (mm)	a <sub>p</sub> (mm)	a <sub>e</sub> (mm)	n (min <sup>-1</sup> )	V <sub>f</sub> (mm/min)	ℓ (mm)	a <sub>p</sub> (mm)	a <sub>e</sub> (mm)	n (min <sup>-1</sup> )	V <sub>f</sub> (mm/min)
Carbon steel (S50C, S55C) below 250HB	JC8050	~70	0.8	~14	1,990	4,780	~90	0.8	~18	1,820	6,550
		~120	0.7	~14	1,790	3,940	~140	0.7	~18	1,640	5,410
		-	-	-	-	-	-	-	-	-	-
Tool & die steel (SKD61, SKD11) below 255HB	JC8050	~70	0.8	~14	1,790	4,300	~90	0.8	~18	1,640	5,900
		~120	0.7	~14	1,590	3,500	~140	0.7	~18	1,460	4,820
		-	-	-	-	-	-	-	-	-	-
Mold steel (HPM7, PX5, P20) 30-36 HRC	JC8118	~70	0.8	~14	1,790	4,300	~90	0.8	~18	1,640	5,900
		~120	0.7	~14	1,590	3,500	~140	0.7	~18	1,460	4,820
		-	-	-	-	-	-	-	-	-	-
Mold steel (NAK80, HPM1, P21) 38-43HRC	JC8118	~70	0.6	~14	1,290	2,580	~90	0.6	~18	1,180	3,540
		~120	0.5	~14	1,090	1,960	~140	0.5	~18	1,000	2,700
		-	-	-	-	-	-	-	-	-	-
Hardened die steel (SKD61, DAC, DHA) 42-52HRC	JC8118	~70	0.6	~14	990	1,780	~90	0.6	~18	910	2,460
		~120	0.5	~14	800	1,280	~140	0.5	~18	730	1,750
		-	-	-	-	-	-	-	-	-	-
Grey cast iron (FC250) 160-260HB	JC8118	~70	1.2	~14	1,990	4,780	~90	1.2	~18	1,820	6,550
		~120	1	~14	1,790	4,300	~140	1	~18	1,640	5,900
		-	-	-	-	-	-	-	-	-	-
Nodular cast iron (FCD700) 170-300HB	JC8118	~70	0.8	~14	1,690	4,060	~90	0.8	~18	1,550	5,580
		~120	0.6	~14	1,490	3,280	~140	0.6	~18	1,360	4,490
		-	-	-	-	-	-	-	-	-	-
Austenitic stainless steel (SUS304, 316, 317) 17Cr	JC8050	~70	0.6	~14	1,490	2,980	~90	0.6	~18	1,360	4,080
		~120	0.5	~14	1,290	2,320	~140	0.5	~18	1,180	3,190
		-	-	-	-	-	-	-	-	-	-
Ferritic & martensitic stainless steel (SUS403 420J2, 430) 13Cr	JC8118	~70	0.8	~14	1,690	3,380	~90	0.8	~18	1,550	4,650
		~120	0.7	~14	1,490	2,680	~140	0.7	~18	1,360	3,670
		-	-	-	-	-	-	-	-	-	-

## Note

1. Please adjust cutting conditions according to machine rigidity or work rigidity. (the above table is guide for cutting on a #50 BT machine.)
2. In case of chatter occurring, recommended to reduce a<sub>p</sub> or rpm and keep feed per tooth.
3. a<sub>p</sub> should be reduced when using on low rigidity machine.
4. Use air blow.

**SKS EXTREME**
**EXSKS/MEX Type**
**■ Recommended cutting conditions**
**● EXSKS07 Endmill shank type**

Material	Grade	Tool dia.(mm)				
		40				
		4N				
		ℓ (mm)	a <sub>p</sub> (mm)	a <sub>e</sub> (mm)	n (min <sup>-1</sup> )	V <sub>f</sub> (mm/min)
Carbon steel (S50C, S55C) below 250HB	JC8050	~90	0.8	~23	1,430	6,860
		~140	0.7	~23	1,350	5,940
		-	-	-	-	-
Tool & die steel (SKD61, SKD11) below 255HB	JC8050	~90	0.8	~23	1,270	6,100
		~140	0.7	~23	1,190	5,240
		-	-	-	-	-
Mold steel (HPM7, PX5, P20) 30-36 HRC	JC8118	~90	0.8	~23	1,270	6,100
		~140	0.7	~23	1,190	5,240
		-	-	-	-	-
Mold steel (NAK80, HPM1, P21) 38-43HRC	JC8118	~90	0.6	~23	880	3,520
		~140	0.5	~23	800	2,880
		-	-	-	-	-
Hardened die steel (SKD61, DAC, DHA) 42-52HRC	JC8118	~90	0.6	~23	720	2,590
		~140	0.5	~23	640	2,050
		-	-	-	-	-
Grey cast iron (FC250) 160-260HB	JC8118	~90	1.2	~23	1,430	6,860
		~140	1	~23	1,350	6,480
		-	-	-	-	-
Nodular cast iron (FCD700) 170-300HB	JC8118	~90	0.8	~23	1,190	5,710
		~140	0.6	~23	1,110	4,880
		-	-	-	-	-
Austenitic stainless steel (SUS304, 316, 317) 17Cr	JC8050	~90	0.6	~23	1,030	4,120
		~140	0.5	~23	950	3,420
		-	-	-	-	-
Ferritic & martensitic stainless steel (SUS403 420J2, 430) 13Cr	JC8118	~90	0.8	~23	1,190	4,760
		~140	0.7	~23	1,110	4,000
		-	-	-	-	-

**Note**

1. Please adjust cutting conditions according to machine rigidity or work rigidity. (the above table is guide for cutting on a #50 BT machine.)
2. In case of chatter occurring, recommended to reduce a<sub>p</sub> or rpm and keep feed per tooth.
3. a<sub>p</sub> should be reduced when using on low rigidity machine.
4. Use air blow.

**SKS EXTREME****EXSKS/MEX Type**

■ Recommended cutting conditions

● EXSKS07 Facemill type

Material	Grade	Tool dia.(mm)									
		50/52					63				
		5N					6N				
		ℓ (mm)	ap (mm)	ae (mm)	n (min <sup>-1</sup> )	Vf (mm/min)	ℓ (mm)	ap (mm)	ae (mm)	n (min <sup>-1</sup> )	Vf (mm/min)
Carbon steel (S50C, S55C) below 250HB	JC8050	~150	1.5	~33	950	7,130	~150	1.5	~46	760	6,840
		200	1.2	~33	950	6,180	200	1.2	~46	760	5,930
		250	1	~33	830	5,400	250	1	~46	660	5,150
		300	0.7	~33	760	4,180	300	0.7	~46	610	4,030
		350	-	-	-	-	350	0.5	~46	610	4,030
Tool & die steel (SKD61, SKD11) below 255HB	JC8050	~150	1.5	~33	830	6,230	~150	1.5	~46	660	5,940
		200	1.2	~33	830	5,400	200	1.2	~46	660	5,150
		250	1	~33	700	4,550	250	1	~46	560	4,370
		300	0.7	~33	640	3,520	300	0.7	~46	510	3,370
		350	-	-	-	-	350	0.5	~46	510	3,370
Mold steel (HPM7, PX5, P20) 30-36 HRC	JC8118	~150	1.5	~33	830	6,230	~150	1.5	~46	660	5,940
		200	1.2	~33	830	5,400	200	1.2	~46	660	5,150
		250	1	~33	700	4,550	250	1	~46	560	4,370
		300	0.7	~33	640	3,520	300	0.7	~46	510	3,370
		350	-	-	-	-	350	0.5	~46	510	3,370
Mold steel (NAK80, HPM1, P21) 38-43HRC	JC8118	~150	1.2	~33	700	4,550	~150	1.2	~46	560	4,370
		200	1	~33	700	3,850	200	1	~46	560	3,700
		250	0.7	~33	570	3,140	250	0.7	~46	450	2,970
		300	0.5	~33	510	2,550	300	0.5	~46	400	2,400
		350	-	-	-	-	350	-	-	-	-
Hardened die steel (SKD61, DAC, DHA) 42-52HRC	JC8118	~150	1	~33	570	2,850	~150	1	~46	450	2,700
		200	0.8	~33	570	2,570	200	0.8	~46	450	2,430
		250	0.6	~33	510	2,300	250	0.6	~46	400	2,160
		300	0.4	~33	450	1,800	300	0.4	~46	350	1,680
		350	-	-	-	-	350	-	-	-	-
Grey cast iron (FC250) 160-260HB	JC8118	~150	2	~33	950	7,130	~150	2	~46	760	6,840
		200	1.5	~33	950	6,180	200	1.5	~46	760	5,930
		250	1	~33	830	5,400	250	1	~46	660	5,150
		300	0.7	~33	760	4,180	300	0.7	~46	610	4,030
		350	-	-	-	-	350	0.5	~46	610	4,030
Nodular cast iron (FCD700) 170-300HB	JC8118	~150	1.5	~33	830	6,230	~150	1.5	~46	660	5,940
		200	1.2	~33	830	5,400	200	1.2	~46	660	5,150
		250	1	~33	700	4,550	250	1	~46	560	4,370
		300	0.7	~33	640	3,520	300	0.7	~46	510	3,370
		350	-	-	-	-	350	0.5	~46	510	3,370
Austenitic stainless steel (SUS304, 316, 317) 17Cr	JC8050	~150	1.2	~33	700	4,550	~150	1.2	~46	560	4,370
		200	1	~33	700	3,850	200	1	~46	560	3,700
		250	0.7	~33	570	3,140	250	0.7	~46	450	2,970
		300	0.5	~33	510	2,550	300	0.5	~46	400	2,400
		350	-	-	-	-	350	0.4	~46	400	2,400
Ferritic & martensitic stainless steel (SUS403 420J2, 430) 13Cr	JC8118	~150	1.5	~33	830	5,400	~150	1.5	~46	660	5,150
		200	1.2	~33	830	4,570	200	1.2	~46	660	4,360
		250	1	~33	700	3,850	250	1	~46	560	3,700
		300	0.7	~33	640	3,200	300	0.7	~46	510	3,060
		350	-	-	-	-	350	0.5	~46	510	3,060

## Note

1. Please adjust cutting conditions according to machine rigidity or work rigidity. (the above table is guide for cutting on a #50 BT machine.)
2. In case of chatter occurring, recommended to reduce ap or rpm and keep feed per tooth.
3. ap should be reduced when using on low rigidity machine.
4. Use air blow.

**SKS EXTREME****EXSKS/MEX Type**

## ■ Recommended cutting conditions

## ● EXSKS07 Facemill type

Material	Grade	Tool dia.(mm)				
		80				
		7N				
		$\phi$ (mm)	$a_p$ (mm)	$a_e$ (mm)	$n$ (min <sup>-1</sup> )	$V_f$ (mm/min)
Carbon steel (S50C, S55C) below 250HB	JC8050	~150	1.5	~63	600	6,300
		200	1.2	~63	600	5,460
		250	1	~63	520	4,730
		300	0.7	~63	480	3,700
		350	0.5	~63	480	3,700
Tool & die steel (SKD61, SKD11) below 255HB	JC8050	~150	1.5	~63	520	5,460
		200	1.2	~63	520	4,730
		250	1	~63	440	4,000
		300	0.7	~63	400	3,080
		350	0.5	~63	400	3,080
Mold steel (HPM7, PX5, P20) 30-36 HRC	JC8118	~150	1.5	~63	520	5,460
		200	1.2	~63	520	4,730
		250	1	~63	440	4,000
		300	0.7	~63	400	3,080
		350	0.5	~63	400	3,080
Mold steel (NAK80, HPM1, P21) 38-43HRC	JC8118	~150	1.2	~63	440	4,000
		200	1	~63	440	3,390
		250	0.7	~63	360	2,770
		300	0.5	~63	320	2,240
		350	-	-	320	2,240
Hardened die steel (SKD61, DAC, DHA) 42-52HRC	JC8118	~150	1	~63	360	2,520
		200	0.8	~63	360	2,270
		250	0.6	~63	320	2,020
		300	0.4	~63	280	1,570
		350	-	-	-	-
Grey cast iron (FC250) 160-260HB	JC8118	~150	2	~63	600	6,300
		200	1.5	~63	600	5,460
		250	1	~63	520	4,730
		300	0.7	~63	480	3,700
		350	0.5	~63	480	3,700
Nodular cast iron (FCD700) 170-300HB	JC8118	~150	1.5	~63	520	5,460
		200	1.2	~63	520	4,730
		250	1	~63	440	4,000
		300	0.7	~63	400	3,080
		350	0.5	~63	400	3,080
Austenitic stainless steel (SUS304, 316, 317) 17Cr	JC8050	~150	1.2	~63	440	4,000
		200	1	~63	440	3,390
		250	0.7	~63	360	2,770
		300	0.5	~63	320	2,240
		350	0.4	~63	320	2,240
Ferritic & martensitic stainless steel (SUS403 420J2, 430) 13Cr	JC8118	~150	1.5	~63	520	4,730
		200	1.2	~63	520	4,000
		250	1	~63	440	3,390
		300	0.7	~63	400	2,800
		350	0.5	~63	400	2,800

## Note

1. Please adjust cutting conditions according to machine rigidity or work rigidity. (the above table is guide for cutting on a #50 BT machine.)
2. In case of chatter occurring, recommended to reduce  $a_p$  or rpm and keep feed per tooth.
3.  $a_p$  should be reduced when using on low rigidity machine.
4. Use air blow.

**SKS EXTREME****EXSKS/MEX Type**

## ■ Recommended cutting conditions

## ● EXSKS09 Type

Material	Grade	Tool dia.(mm)														
		50					50/52					63				
		3N					4N					4N				
		ℓ (mm)	a <sub>p</sub> (mm)	n (min <sup>-1</sup> )	V <sub>f</sub> (mm/min)	P <sub>c</sub> (kW)	ℓ (mm)	a <sub>p</sub> (mm)	n (min <sup>-1</sup> )	V <sub>f</sub> (mm/min)	P <sub>c</sub> (kW)	ℓ (mm)	a <sub>p</sub> (mm)	n (min <sup>-1</sup> )	V <sub>f</sub> (mm/min)	P <sub>c</sub> (kW)
Carbon steel (S50C, S55C) below 250HB	JC7560 JC8050 (JC8118)	~150	2	950	5,700	9.3	~150	2	950	7,600	12.4	~150	2	750	6,000	12.3
		200	1.5	800	4,800	5.9	200	1.5	800	6,400	7.8	200	1.8	680	5,440	10.0
		250	1	650	2,925	2.4	250	1	650	3,900	3.2	250	1.5	600	4,800	7.4
		300	0.6	650	1,950	1.0	300	0.6	650	2,600	1.3	300	1	550	4,400	4.5
		350	—	—	—	—	350	—	—	—	—	350	0.6	550	3,300	2.0
400	—	—	—	—	400	—	—	—	—	400	0.4	550	2,200	0.9		
Tool & die steel (SKD61, SKD11) below 255HB	JC7560 JC8050 (JC8118)	~150	2	950	5,700	9.3	~150	2	950	7,600	12.4	~150	2	750	6,000	12.3
		200	1.5	800	4,800	5.9	200	1.5	800	6,400	7.8	200	1.8	680	5,440	10.0
		250	1	650	2,925	2.4	250	1	650	3,900	3.2	250	1.5	600	4,800	7.4
		300	0.6	650	1,950	1.0	300	0.6	650	2,600	1.3	300	1	550	4,400	4.5
		350	—	—	—	—	350	—	—	—	—	350	0.6	550	3,300	2.0
400	—	—	—	—	400	—	—	—	—	400	0.4	550	2,200	0.9		
Mold steel (HPM7, PX5, P20) 30-36 HRC	JC7560 JC8050 (JC8118)	~150	2	830	4,980	9.2	~150	2	830	6,640	12.3	~150	2	650	5,200	12.2
		200	1.5	700	4,200	5.9	200	1.5	700	5,600	7.8	200	1.8	580	4,640	9.8
		250	1	570	2,565	2.4	250	1	570	3,420	3.2	250	1.5	520	4,160	7.3
		300	0.6	570	1,710	1.0	300	0.6	570	2,280	1.3	300	1	460	3,680	4.3
		350	—	—	—	—	350	—	—	—	—	350	0.6	460	2,760	1.9
400	—	—	—	—	400	—	—	—	—	400	0.4	460	1,840	0.9		
Mold steel (NAK80, HPM1, P21) 38-43HRC	JC8118 (JC8050)	~150	1.5	700	2,100	5.1	~150	1.5	700	2,800	6.8	~150	1.5	550	2,200	6.8
		200	1	600	1,800	2.9	200	1	600	2,400	3.9	200	1.2	500	2,000	4.9
		250	0.7	490	1,470	1.7	250	0.7	490	1,960	2.2	250	1	440	1,760	3.6
		300	0.4	490	735	0.5	300	0.4	490	980	0.6	300	0.7	380	1,520	2.2
		350	—	—	—	—	350	—	—	—	—	350	0.5	380	1,520	1.6
400	—	—	—	—	400	—	—	—	—	400	—	—	—	—		
Hardened die steel (SKD61, DAC, DHA) 42-52HRC	JC8118	~150	1.5	510	1,530	5.0	~150	1.5	510	2,040	6.6	~150	1.5	400	1,600	6.6
		200	1	460	1,380	3.0	200	1	460	1,840	4.0	200	1.2	360	1,440	4.7
		250	0.7	420	1,260	1.9	250	0.7	420	1,680	2.5	250	1	320	1,280	3.5
		300	0.4	420	630	0.5	300	0.4	420	840	0.7	300	0.7	280	1,120	2.1
		350	—	—	—	—	350	—	—	—	—	350	0.5	280	1,120	1.5
400	—	—	—	—	400	—	—	—	—	400	—	—	—	—		
Grey cast iron (FC250, FC300) below 300HB	JC8118	~150	2.5	950	5,700	9.3	~150	2.5	950	7,600	12.4	~150	2.5	750	6,000	12.3
		200	2	800	4,800	6.2	200	2	800	6,400	8.3	200	2	680	5,440	8.9
		250	1.5	650	2,925	2.9	250	1.5	650	3,900	3.8	250	1.5	600	4,800	5.9
		300	1	650	1,950	1.3	300	1	650	2,600	1.7	300	1	550	4,400	3.6
		350	—	—	—	—	350	—	—	—	—	350	0.6	550	3,300	1.6
400	—	—	—	—	400	—	—	—	—	400	0.4	550	2,200	0.7		
Nodular cast iron (FCD500, FCD700) below 300HB	JC8118	~150	2.5	950	5,700	9.3	~150	2.5	950	7,600	12.4	~150	2.5	750	6,000	12.3
		200	2	800	4,800	6.2	200	2	800	6,400	8.3	200	2	680	5,440	8.9
		250	1.5	650	2,925	2.9	250	1.5	650	3,900	3.8	250	1.5	600	4,800	5.9
		300	1	650	1,950	1.3	300	1	650	2,600	1.7	300	1	550	4,400	3.6
		350	—	—	—	—	350	—	—	—	—	350	0.6	550	3,300	1.6
400	—	—	—	—	400	—	—	—	—	400	0.4	550	2,200	0.7		
Stainless steel (SUS304) below 250HB	JC8050 (JC7560)	~150	2	950	4,275	11.1	~150	2	950	5,700	14.8	~150	2	750	4,500	14.7
		200	1.5	800	3,600	7.0	200	1.5	800	4,800	9.4	200	1.8	680	4,080	12.0
		250	1	650	1,950	2.5	250	1	650	2,600	3.4	250	1.5	600	3,600	8.8
		300	0.6	650	1,950	1.5	300	0.6	650	2,600	2.0	300	1	550	2,640	4.3
		350	—	—	—	—	350	—	—	—	—	350	0.6	550	2,200	2.2
400	—	—	—	—	400	—	—	—	—	400	0.4	550	2,200	1.4		

## Note

1. Please adjust cutting conditions according to machine rigidity or work rigidity. (the above table is guide for cutting on a #50 BT machine.)
2. In case of chatter occurring, recommended to reduce a<sub>p</sub> or rpm and keep feed per tooth.
3. a<sub>p</sub> should be reduced when using on low rigidity machine.
4. Use air blow.
5. a<sub>p</sub> ≤ 2mm when using PL insert.

**SKS EXTREME**

**EXSKS/MEX Type**

- Recommended cutting conditions
- EXSKS09 Type

Material	Grade	Tool dia.(mm)														
		63/66					80					100				
		5N					6N					7N				
		ℓ (mm)	ap (mm)	n (min <sup>-1</sup> )	Vf (mm/min)	Pc (kW)	ℓ (mm)	ap (mm)	n (min <sup>-1</sup> )	Vf (mm/min)	Pc (kW)	ℓ (mm)	ap (mm)	n (min <sup>-1</sup> )	Vf (mm/min)	Pc (kW)
Carbon steel (S50C, S55C) below 250HB	JC7560 JC8050 (JC8118)	~150	2	750	7,500	15.4	~150	2	600	7,200	18.7	~150	2	480	6,720	21.8
		200	1.8	680	6,800	12.5	200	1.8	540	6,480	15.2	200	2	430	6,020	19.6
		250	1.5	600	6,000	9.2	250	1.8	480	5,760	13.5	250	2	380	5,320	17.3
		300	1	550	5,500	5.6	300	1.5	440	5,280	10.3	300	1.5	350	4,900	11.9
		350	0.6	550	4,125	2.5	350	1	440	5,280	6.9	350	1.5	350	4,900	11.9
400	0.4	550	2,750	1.1	400	0.6	440	3,960	3.1	400	1	350	4,900	8.0		
Tool & die steel (SKD61, SKD11) below 255HB	JC7560 JC8050 (JC8118)	~150	2	750	7,500	15.4	~150	2	600	7,200	18.7	~150	2	480	6,720	21.8
		200	1.8	680	6,800	12.5	200	1.8	540	6,480	15.2	200	2	430	6,020	19.6
		250	1.5	600	6,000	9.2	250	1.8	480	5,760	13.5	250	2	380	5,320	17.3
		300	1	550	5,500	5.6	300	1.5	440	5,280	10.3	300	1.5	350	4,900	11.9
		350	0.6	550	4,125	2.5	350	1	440	5,280	6.9	350	1.5	350	4,900	11.9
400	0.4	550	2,750	1.1	400	0.6	440	3,960	3.1	400	1	350	4,900	8.0		
Mold steel (HPM7, PX5, P20) 30-36 HRC	JC7560 JC8050 (JC8118)	~150	2	650	6,500	15.2	~150	2	520	6,240	18.5	~150	2	410	5,740	21.3
		200	1.8	580	5,800	12.2	200	1.8	470	5,640	15.1	200	2	370	5,180	19.2
		250	1.5	520	5,200	9.1	250	1.8	420	5,040	13.5	250	2	330	4,620	17.2
		300	1	460	4,600	5.4	300	1.5	360	4,320	9.6	300	1.5	280	3,920	10.9
		350	0.6	460	3,450	2.4	350	1	360	4,320	6.4	350	1.5	280	3,920	10.9
400	0.4	460	2,300	1.1	400	0.6	360	3,240	2.9	400	1	280	3,920	7.3		
Mold steel (NAK80, HPM1, P21) 38-43HRC	JC8118 (JC8050)	~150	1.5	550	2,750	8.4	~150	1.5	430	2,580	10.1	~150	1.5	350	2,450	11.9
		200	1.2	500	2,500	6.1	200	1.2	390	2,340	7.3	200	1.5	310	2,170	10.6
		250	1	440	2,200	4.5	250	1.2	340	2,040	6.4	250	1.2	280	1,960	7.6
		300	0.7	380	1,900	2.7	300	1	300	1,800	4.7	300	1	250	1,750	5.7
		350	0.5	380	1,900	1.9	350	0.7	300	1,800	3.3	350	1	250	1,750	5.7
400	—	—	—	—	400	0.4	300	1,800	1.9	400	0.7	250	1,750	4.0		
Hardened die steel (SKD61, DAC, DHA) 42-52HRC	JC8118	~150	1.5	400	2,000	8.2	~150	1.5	320	1,920	10.0	~150	1.5	250	1,750	11.4
		200	1.2	360	1,800	5.9	200	1.2	290	1,740	7.2	200	1.5	230	1,610	10.5
		250	1	320	1,600	4.4	250	1.2	260	1,560	6.5	250	1.2	200	1,400	7.3
		300	0.7	280	1,400	2.7	300	1	220	1,320	4.6	300	1	180	1,260	5.5
		350	0.5	280	1,400	1.9	350	0.7	220	1,320	3.2	350	1	180	1,260	5.5
400	—	—	—	—	400	0.4	220	1,320	1.8	400	0.7	180	1,260	3.8		
Grey cast iron (FC250, FC300) below 300HB	JC8118	~150	2.5	750	7,500	15.4	~150	2.5	600	7,200	18.7	~150	2.5	480	6,720	21.8
		200	2	680	6,800	11.1	200	2	540	6,480	13.5	200	2.5	430	6,020	19.6
		250	1.5	600	6,000	7.4	250	2	480	5,760	12.0	250	2	380	5,320	13.8
		300	1	550	5,500	4.5	300	1.5	440	5,280	8.2	300	2	350	4,900	12.7
		350	0.6	550	4,125	2.0	350	1	440	5,280	5.5	350	1.5	350	4,900	9.6
400	0.4	550	2,750	0.9	400	0.6	440	3,960	2.5	400	1	350	4,900	6.4		
Nodular cast iron (FCD500, FCD700) below 300HB	JC8118	~150	2.5	750	7,500	15.4	~150	2.5	600	7,200	18.7	~150	2.5	480	6,720	21.8
		200	2	680	6,800	11.1	200	2	540	6,480	13.5	200	2.5	430	6,020	19.6
		250	1.5	600	6,000	7.4	250	2	480	5,760	12.0	250	2	380	5,320	13.8
		300	1	550	5,500	4.5	300	1.5	440	5,280	8.2	300	2	350	4,900	12.7
		350	0.6	550	4,125	2.0	350	1	440	5,280	5.5	350	1.5	350	4,900	9.6
400	0.4	550	2,750	0.9	400	0.6	440	3,960	2.5	400	1	350	4,900	6.4		
Stainless steel (SUS304) below 250HB	JC8050 (JC7560)	~150	2	750	5,625	18.4	~150	2	600	5,400	22.5	~150	2	480	5,040	26.2
		200	1.8	680	5,100	15.0	200	1.8	540	4,860	18.2	200	2	430	4,515	23.5
		250	1.5	600	4,500	11.1	250	1.8	480	4,320	16.2	250	2	380	3,990	20.7
		300	1	550	3,300	5.4	300	1.5	440	3,960	12.4	300	1.5	350	3,675	14.3
		350	0.6	550	2,750	2.7	350	1	440	3,168	6.6	350	1.5	350	3,675	14.3
400	0.4	550	2,750	1.8	400	0.6	440	2,640	3.3	400	1	350	3,675	9.6		

Note

1. Please adjust cutting conditions according to machine rigidity or work rigidity. (the above table is guide for cutting on a #50 BT machine.)
2. In case of chatter occurring, recommended to reduce ap or rpm and keep feed per tooth.
3. ap should be reduced when using on low rigidity machine.
4. Use air blow.
5. ap ≤ 2mm when using PL insert.