

SIC-EVO

SSV Type

進化した。SIC-EVO



Feature 1

Max. depth of cut (ap) =15mm is possible.

Usable for a wide range of applications such as face milling, slotting, pocket milling & side milling.

Arc geometry on peripheral cutting edge

Cusp height can be smaller even in case of large ap. achieves high efficient & high precision machining for vertical walls.



High positive geometry with low cutting force

Capable of ramping & helical interpolation

Feature 2

Available corner radius: R0.4, R0.8, R1.6, R2.0 & R3.0

■ Insert grades

ISO	P					M					K				H		
	P01	P10	P20	P30	P40	M01	M10	M20	M30	M40	K01	K10	K20	K30	H01	H10	H20
Range	JC8118					JC8118					JC8118				JC8118		
	JC8050					JC8050											

SIC-EVO

SSV Type

■ **Facemill Type**

Through coolant hole

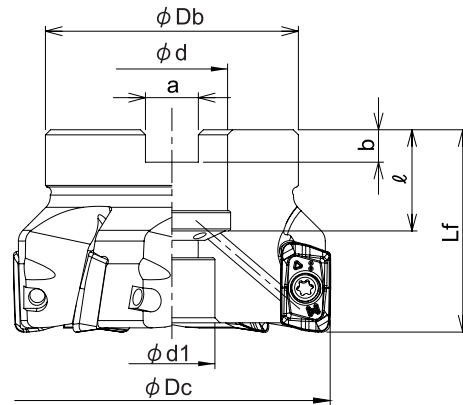

Cat.No.	Stock	No. of inserts	Dimensions (mm)								Arbor set bolt	Weight (kg)	Insert
			ϕDc	Lf	ϕDb	ϕd	$\phi d1$	a	b	ℓ			
SSV-4040R-16	●	4	40	40	35	16	14	8.4	5.6	18	M8	0.20	ZOMT1605**ZER-PM
SSV-5050R-22	●	5	50		47	22	17	10.4	6.3	20	M10	0.33	
SSV-6063R-22	●	6	63		50	20	12.4	7	22	M12X1.75X30*	0.75		
SSV-6063R-27	●			60	27						20	12.4	
SSV-7080R-27	●	7	80	50	60	27	20	12.4	7	22	M12X1.75X30	1.08	
SSV-8100R-32	●	8	100		85	32	26	14.4	8	25	M16X2X30*	1.95	
SSV-8125R-40	●		125	63	100	40	32	16.4	9	32	M20X2.5X40*	3.73	

Screw	Torque(N.m)	Wrench
DSW-4075H	3.6	A-15T

SIC-EVO **SSV Type**

■ **Modular Head Type**

Through coolant hole

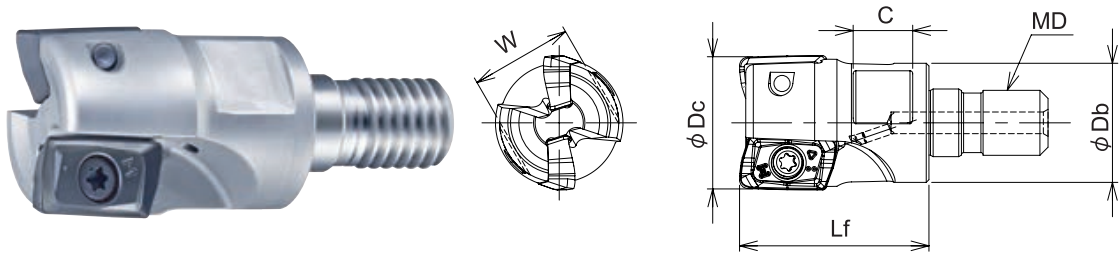

Cat.No.	Stock	No. of inserts	Dimensions (mm)						Insert
			φDc	Lf	φDb	MD	C	W	
SSV-2025-M12	●	2	25	35	22	M12	11	19	ZOMT1605**ZER-PM
SSV-2028-M12	●		28						
SSV-3030-M16	●	3	30	43	29	M16	12	22	
SSV-3032-M16	●		32						
SSV-3035-M16	●		35						
SSV-4040-M16	●	4	40						

Screw	Torque(N.m)	Wrench
DSW-4075H	3.6	A-15T

SIC-EVO

SSV Type

■ **Endmill Shank Type**

Through coolant hole

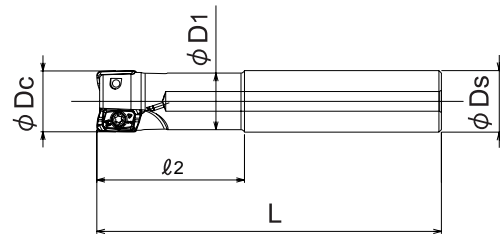

Cat.No.	Stock	No. of inserts	Dimensions (mm)					Parts		Insert
			ϕD_c	ℓ_2	L	ϕD_1	ϕD_s	Wrench		
SSV-2025-60-S25+A	●	2	25	60	140	23	25	A-15	ZOMT1605**ZER-PM	
SSV-2025-100-S25+A	●			100	180					
SSV-3032-70-S32+A	●	3	32	70	150	29	32			
SSV-3032-120-S32+A	●	3		120	200					
SSV-4040-50-S32+A	●	4	40	50	150	37				

Screw	Torque(N.m)	Wrench
DSW-4075H	3.6	A-15

SIC-EVO **SSV Type**

■ **Insert**

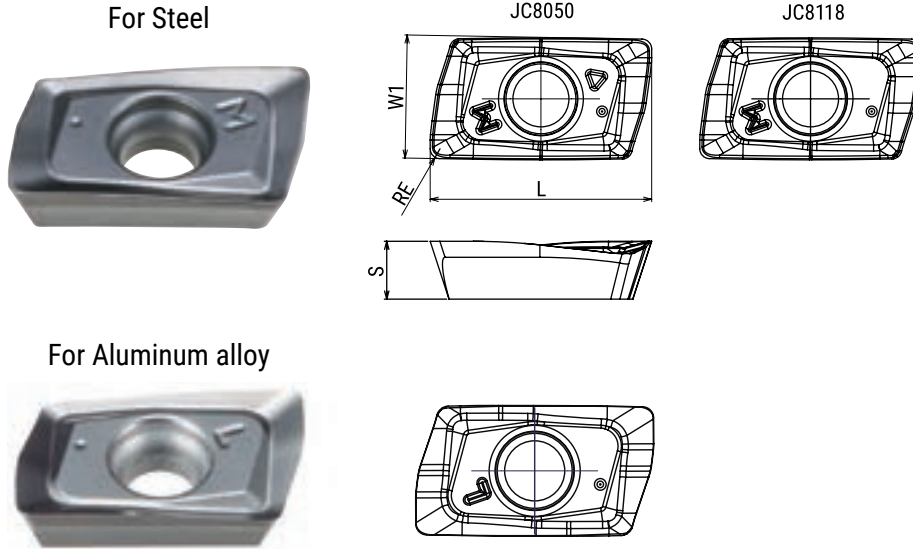

Cat.No.	Tolerance	PVD Coating		Uncoated	Dimensions (mm)			
		JC8050	JC8118	FC18	RE	L	W1	S
ZOMT160504ZER-PM	M	●	●		0.4	18	10	4.7
ZOMT160508ZER-PM		●	●		0.8			
ZOMT160516ZER-PM		●	●		1.6			
ZOMT160520ZER-PM		●	●		2			
ZOMT160530ZER-PM		●	●		3			
ZOET160508ZFR-NL	E			●	0.8			

GRADE MARKINGS

JC8050

JC8118

ZOMT160504ZER-PM

ZOMT160508ZER-PM

ZOMT160516ZER-PM

ZOMT160520ZER-PM

ZOMT160530ZER-PM

SIC-EVO

SSV Type

Recommended Data for Profile Milling

Ramping

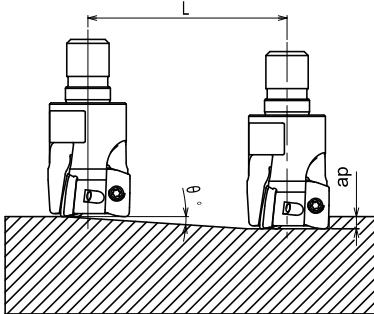

Helical interpolation

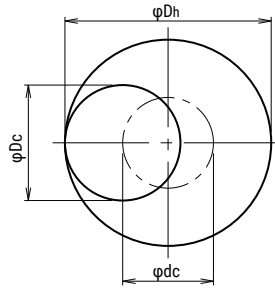
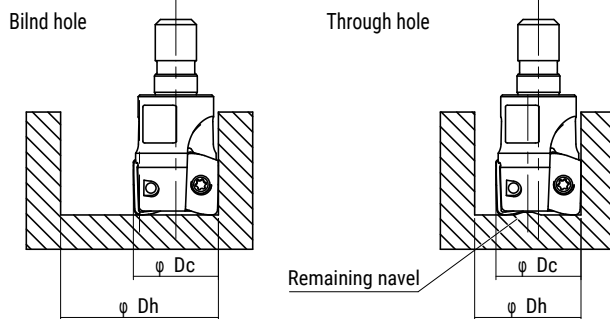

- In case of ramping and helical interpolation, apply 80% or less feed (Vf) from standard cutting condition table
- In case of drilling, apply 50% or less feed (Vf) from standard cutting condition table
- In case of helical interpolation, recommend wet cutting by coolant through the tool
- Long chips may come out in case of drilling, confirm safe operating conditions

- Calculation of tool pass dia.

$$\phi_{dc} = \phi_{Dh} - \phi_{Dc}$$

Tool pass dia. Bore dia. Tool Dia.

- Depth of cut per one circuit should not exceed max. depth of cut Ap
- Down cutting is recommended, tool pass rotation should be counterclockwise

ZOMT160504ZER-PM

Cat.No.	Tool dia. (mm)	Effective cutting dia. (mm)	Max.depth of cut : ap (mm)	Ramping		Helical interpolation			Max. drilling depth: Z
				Max. ramping angle θ	Max. depth of cut (ap) Total cutting length L(mm)	Through hole Min. Bore dia. (mm)	Blind hole Min. Bore dia. (mm)	Blind hole Max. Bore dia. (mm)	
SSV-2025-**	25	23.9	1.5	6.2	13.8	31	48	48.8	1.6
SSV-2028-M12	28	26.9	1.5	5.3	16.2	37	54	54.8	1.6
SSV-3030-**	30	28.9	1.5	4.8	17.9	41	58	58.8	1.6
SSV-3032-**	32	30.9	1.5	4.4	19.5	45	62	62.8	1.6
SSV-3035-M16	35	33.9	1.5	4.3	19.9	51	68	68.8	1.6
SSV-4040-**	40	38.9	1.5	3.6	23.8	61	78	78.8	1.6
SSV-5050R-**	50	48.9	1.5	2.4	35.8	81	98	98.8	1.4
SSV-6063R-**	63	61.9	1.5	1.7	50.5	107	124	124.8	1.4
SSV-7080R-**	80	78.9	1.5	1.2	71.6	141	158	158.8	1.4
SSV-8100R-**	100	98.9	1.5	0.9	95.5	181	198	198.8	1.4
SSV-8125R-**	125	123.9	1.5	0.65	132.2	231	248	248.8	1.4

ZOMT160508ZER-PM

Cat.No.	Tool dia. (mm)	Effective cutting dia. (mm)	Max.depth of cut : ap (mm)	Ramping		Helical interpolation			Max. drilling depth: Z
				Max. ramping angle θ	Max. depth of cut (ap) Total cutting length L(mm)	Through hole Min. Bore dia. (mm)	Blind hole Min. Bore dia. (mm)	Blind hole Max. Bore dia. (mm)	
SSV-2025-**	25	23.1	1.5	6.4	13.4	31	47.2	48	1.6
SSV-2028-M12	28	26.1	1.5	5.4	15.9	37	53.2	54	1.6
SSV-3030-**	30	28.1	1.5	4.8	17.9	41	57.2	58	1.6
SSV-3032-**	32	30.1	1.5	4.4	19.5	45	61.2	62	1.6
SSV-3035-M16	35	33.1	1.5	4.3	19.9	51	67.2	68	1.6
SSV-4040-**	40	38.1	1.5	3.6	23.8	61	77.2	78	1.6
SSV-5050R-**	50	48.1	1.5	2.4	35.8	81	97.2	98	1.4
SSV-6063R-**	63	61.1	1.5	1.7	50.5	107	123.2	124	1.4
SSV-7080R-**	80	78.1	1.5	1.2	71.6	141	157.2	158	1.4
SSV-8100R-**	100	98.1	1.5	0.9	95.5	181	197.2	198	1.4
SSV-8125R-**	125	123.1	1.5	0.65	132.2	231	247.2	248	1.4

SIC-EVO**SSV Type****ZOMT160516ZER-PM**

Cat.No.	Tool dia. (mm)	Effective cutting dia. (mm)	Max.depth of cut: ap (mm)	Ramping		Helical interpolation			Max. drilling depth: Z
				Max. ramping angle θ	Max. depth of cut (ap) Total cutting length L(mm)	Through hole Min. Bore dia. (mm)	Blind hole Min. Bore dia. (mm)	Blind hole Max. Bore dia. (mm)	
SSV-2025-**	25	21.5	1.5	6.7	12.8	31	45.8	46.4	1.5
SSV-2028-M12	28	24.5	1.5	5.6	15.3	37	51.8	52.4	1.5
SSV-3030-**	30	26.5	1.5	5	17.1	41	55.8	56.4	1.5
SSV-3032-**	32	28.5	1.5	4.7	18.2	45	59.8	60.4	1.5
SSV-3035-M16	35	31.5	1.5	4.6	18.6	51	65.8	66.4	1.5
SSV-4040-**	40	36.5	1.5	3.8	22.6	61	75.8	76.4	1.5
SSV-5050R-**	50	46.5	1.5	2.5	34.4	81	95.8	96.4	1.4
SSV-6063R-**	63	59.5	1.5	1.8	47.7	107	121.8	122.4	1.4
SSV-7080R-**	80	76.5	1.5	1.2	71.6	141	155.8	156.4	1.4
SSV-8100R-**	100	96.5	1.5	0.9	95.5	181	195.8	196.4	1.4
SSV-8125R-**	125	121.5	1.5	0.65	132.2	231	245.8	246.4	1.4

ZOMT160520ZER-PM

Cat.No.	Tool dia. (mm)	Effective cutting dia. (mm)	Max.depth of cut: ap (mm)	Ramping		Helical interpolation			Max. drilling depth: Z
				Max. ramping angle θ	Max. depth of cut (ap) Total cutting length L(mm)	Through hole Min. Bore dia. (mm)	Blind hole Min. Bore dia. (mm)	Blind hole Max. Bore dia. (mm)	
SSV-2025-**	25	20.7	1.5	6.9	12.4	31	45	45.6	1.5
SSV-2028-M12	28	23.7	1.5	5.7	15.0	37	51	51.6	1.5
SSV-3030-**	30	25.7	1.5	5	17.1	41	55	55.6	1.5
SSV-3032-**	32	27.7	1.5	4.7	18.2	45	59	59.6	1.5
SSV-3035-M16	35	30.7	1.5	4.6	18.6	51	65	65.6	1.5
SSV-4040-**	40	35.7	1.5	3.8	22.6	61	75	75.6	1.5
SSV-5050R-**	50	45.7	1.5	2.5	34.4	81	95	95.6	1.4
SSV-6063R-**	63	58.7	1.5	1.8	47.7	107	121	121.6	1.4
SSV-7080R-**	80	75.7	1.5	1.2	71.6	141	155	155.6	1.4
SSV-8100R-**	100	95.7	1.5	0.9	95.5	181	195	195.6	1.4
SSV-8125R-**	125	120.7	1.5	0.65	132.2	231	245	245.6	1.4

ZOMT160530ZER-PM

Cat.No.	Tool dia. (mm)	Effective cutting dia. (mm)	Max.depth of cut: ap (mm)	Ramping		Helical interpolation			Max. drilling depth: Z
				Max. ramping angle θ	Max. depth of cut (ap) Total cutting length L(mm)	Through hole Min. Bore dia. (mm)	Blind hole Min. Bore dia. (mm)	Blind hole Max. Bore dia. (mm)	
SSV-2025-**	25	18.7	1.5	7.2	11.9	31	43	43.6	1.5
SSV-2028-M12	28	21.7	1.5	6	14.3	37	49	49.6	1.5
SSV-3030-**	30	23.7	1.5	5.3	16.2	41	53	53.6	1.5
SSV-3032-**	32	25.7	1.5	4.8	17.9	45	57	57.6	1.5
SSV-3035-M16	35	28.7	1.5	4.7	18.2	51	63	63.6	1.5
SSV-4040-**	40	33.7	1.5	3.9	22.0	61	73	73.6	1.5
SSV-5050R-**	50	43.7	1.5	2.5	34.4	81	93	93.6	1.4
SSV-6063R-**	63	56.7	1.5	1.8	47.7	107	119	119.6	1.4
SSV-7080R-**	80	73.7	1.5	1.3	66.1	141	153	153.6	1.4
SSV-8100R-**	100	93.7	1.5	0.95	90.5	181	193	193.6	1.4
SSV-8125R-**	125	118.7	1.5	0.65	132.2	231	243	243.6	1.4

SIC-EVO
SSV Type
■ Recommended cutting conditions
● Facemill type - Shoulder milling

Material	Grade	Tool dia.(mm)									
		40					50				
		4N					5N				
		l (mm)	a_p (mm)	$a_p \times a_e$ (mm ²)	n (min ⁻¹)	V_f (mm/min)	l (mm)	a_p (mm)	$a_p \times a_e$ (mm ²)	n (min ⁻¹)	V_f (mm/min)
Carbon steel (S50C, S55C) below 250HB	JC8050	~100	~15.0	~30	1,590	1,910	~100	~15.0	~40	1,270	1,910
		150	~12.0	~20	1,430	1,430	150	~12.0	~25	1,150	1,440
		200	~10.0	~12	1,270	1,020	200	~10.0	~15	1,020	1,020
Cast steel (GM190, ICD5) below 285HB	JC8050	~100	~15.0	~30	1,430	1,720	~100	~15.0	~40	1,150	1,730
		150	~12.0	~20	1,270	1,270	150	~12.0	~25	1,020	1,280
		200	~10.0	~12	1,110	890	200	~10.0	~15	890	890
Tool & die steel (SKD61, SKD11) below 255HB	JC8050	~100	~15.0	~30	1,590	1,910	~100	~15.0	~40	1,270	1,910
		150	~12.0	~20	1,430	1,430	150	~12.0	~25	1,150	1,440
		200	~10.0	~12	1,270	1,020	200	~10.0	~15	1,020	1,020
Mold steel (HPM7, PX5, P20) 30-36 HRC	JC8118	~100	~15.0	~30	1,190	1,430	~100	~15.0	~40	950	1,430
		150	~12.0	~20	1,070	1,070	150	~12.0	~25	860	1,080
		200	~10.0	~12	950	760	200	~10.0	~15	760	760
Mold steel (NAK80, HPM1, P21) 38-43HRC	JC8118	~100	~15.0	~20	950	950	~100	~15.0	~30	760	950
		150	~12.0	~15	840	670	150	~12.0	~20	670	670
		200	~10.0	~8	720	430	200	~10.0	~12	570	430
Hardened die steel (SKD61, DAC, DHA) 42-52HRC	JC8118	~100	~12.0	~12	800	640	~100	~15.0	~18	640	640
		150	~10.0	~8	720	430	150	~12.0	~12	570	430
		200	~8.0	~3	640	260	200	~10.0	~5	510	260
Grey cast iron (FC250) 160-260HB	JC8118	~100	~15.0	~30	1,990	2,390	~100	~15.0	~40	1,590	2,390
		150	~12.0	~20	1,830	1,830	150	~12.0	~25	1,460	1,830
		200	~10.0	~12	1,670	1,340	200	~10.0	~15	1,340	1,340
Nodular cast iron (FCD700) 170-300HB	JC8118	~100	~15.0	~30	1,190	1,190	~100	~15.0	~40	950	1,190
		150	~12.0	~20	1,030	820	150	~12.0	~25	830	830
		200	~10.0	~12	880	530	200	~10.0	~15	700	530
Austenitic stainless steel (SUS304, 316, 317) 17Cr	JC8050	~100	~15.0	~30	950	760	~100	~15.0	~40	760	760
		150	~12.0	~20	880	530	150	~12.0	~25	700	530
		200	~10.0	~12	800	320	200	~10.0	~15	640	320
Ferritic & martensitic stainless steel (SUS403, 420J2, 430) 13Cr	JC8118	~100	~15.0	~30	1,430	1,430	~100	~15.0	~40	1,150	1,440
		150	~12.0	~20	1,270	1,020	150	~12.0	~25	1,020	1,020
		200	~10.0	~12	1,110	670	200	~10.0	~15	890	670

Note

1. Please adjust cutting conditions according to machine rigidity or work rigidity.
2. In case of chatter occurring, recommended to reduce a_p or rpm and keep feed per tooth.
3. a_p should be reduced when using on low rigidity machine.
4. Use air blow.

SIC-EVO**SSV Type**

- Recommended cutting conditions
- Facemill type - Shoulder milling

Material	Grade	Tool dia.(mm)									
		63					80				
		6N					7N				
		ℓ (mm)	a_p (mm)	$a_p \times a_e$ (mm ²)	n (min ⁻¹)	V_f (mm/min)	ℓ (mm)	a_p (mm)	$a_p \times a_e$ (mm ²)	n (min ⁻¹)	V_f (mm/min)
Carbon steel (S50C, S55C) below 250HB	JC8050	~100	~15.0	~45	1,010	2,120	~100	~15.0	~45	800	1,960
		150	~12.0	~30	910	1,640	150	~12.0	~30	720	1,510
		200	~10.0	~20	810	1,220	200	~10.0	~20	640	1,120
Cast steel (GM190, ICD5) below 285HB	JC8050	~100	~15.0	~45	910	1,910	~100	~15.0	~45	720	1,760
		150	~12.0	~30	810	1,460	150	~12.0	~30	640	1,340
		200	~10.0	~20	710	1,070	200	~10.0	~20	560	980
Tool & die steel (SKD61, SKD11) below 255HB	JC8050	~100	~15.0	~45	1,010	2,120	~100	~15.0	~45	800	1,960
		150	~12.0	~30	910	1,640	150	~12.0	~30	720	1,510
		200	~10.0	~20	810	1,220	200	~10.0	~20	640	1,120
Mold steel (HPM7, PX5, P20) 30-36 HRC	JC8118	~100	~15.0	~45	760	1,600	~100	~15.0	~45	600	1,470
		150	~12.0	~30	680	1,220	150	~12.0	~30	540	1,130
		200	~10.0	~20	610	920	200	~10.0	~20	480	840
Mold steel (NAK80, HPM1, P21) 38-43HRC	JC8118	~100	~15.0	~30	610	920	~100	~15.0	~30	480	840
		150	~12.0	~25	530	640	150	~12.0	~25	420	590
		200	~10.0	~15	450	410	200	~10.0	~15	360	380
Hardened die steel (SKD61, DAC, DHA) 42-52HRC	JC8118	~100	~15.0	~25	510	610	~100	~15.0	~25	400	560
		150	~12.0	~15	450	410	150	~12.0	~15	360	380
		200	~10.0	~8	400	240	200	~10.0	~8	320	220
Grey cast iron (FC250) 160-260HB	JC8118	~100	~15.0	~45	1,260	2,650	~100	~15.0	~45	990	2,430
		150	~12.0	~30	1,160	2,090	150	~12.0	~30	920	1,930
		200	~10.0	~20	1,060	1,590	200	~10.0	~20	840	1,470
Nodular cast iron (FCD700) 170-300HB	JC8118	~100	~15.0	~45	760	1,370	~100	~15.0	~45	600	1,260
		150	~12.0	~30	660	990	150	~12.0	~30	520	910
		200	~10.0	~20	560	670	200	~10.0	~20	440	620
Austenitic stainless steel (SUS304, 316, 317) 17Cr	JC8050	~100	~15.0	~45	610	730	~100	~15.0	~45	480	670
		150	~12.0	~30	560	500	150	~12.0	~30	440	460
		200	~10.0	~20	510	310	200	~10.0	~20	400	280
Ferritic & martensitic stainless steel (SUS403, 420J2, 430) 13Cr	JC8118	~100	~15.0	~45	910	1,640	~100	~15.0	~45	720	1,510
		150	~12.0	~30	810	1,220	150	~12.0	~30	640	1,120
		200	~10.0	~20	710	850	200	~10.0	~20	560	780

Note

1. Please adjust cutting conditions according to machine rigidity or work rigidity.
2. In case of chatter occurring, recommended to reduce a_p or rpm and keep feed per tooth.
3. a_p should be reduced when using on low rigidity machine.
4. Use air blow.

SIC-EVO**SSV Type**

■ Recommended cutting conditions

● Facemill type - Shoulder milling

Material	Grade	Tool dia.(mm)									
		100					125				
		8N					8N				
		l (mm)	a_p (mm)	$a_p \times a_e$ (mm ²)	n (min ⁻¹)	V_f (mm/min)	l (mm)	a_p (mm)	$a_p \times a_e$ (mm ²)	n (min ⁻¹)	V_f (mm/min)
Carbon steel (S50C, S55C) below 250HB	JC8050	~100	~15.0	~45	640	1,790	~100	~15.0	~45	510	1,430
		150	~12.0	~30	570	1,370	150	~12.0	~30	460	1,100
		200	~10.0	~20	510	1,020	200	~10.0	~20	410	820
Cast steel (GM190, ICD5) below 285HB	JC8050	~100	~15.0	~45	570	1,600	~100	~15.0	~45	460	1,290
		150	~12.0	~30	510	1,220	150	~12.0	~30	410	980
		200	~10.0	~20	450	900	200	~10.0	~20	360	720
Tool & die steel (SKD61, SKD11) below 255HB	JC8050	~100	~15.0	~45	640	1,790	~100	~15.0	~45	510	1,430
		150	~12.0	~30	570	1,370	150	~12.0	~30	460	1,100
		200	~10.0	~20	510	1,020	200	~10.0	~20	410	820
Mold steel (HPM7, PX5, P20) 30-36 HRC	JC8118	~100	~15.0	~45	480	1,340	~100	~15.0	~45	380	1,060
		150	~12.0	~30	430	1,030	150	~12.0	~30	340	820
		200	~10.0	~20	380	760	200	~10.0	~20	310	620
Mold steel (NAK80, HPM1, P21) 38-43HRC	JC8118	~100	~15.0	~30	380	760	~100	~15.0	~30	310	620
		150	~12.0	~25	330	530	150	~12.0	~25	270	430
		200	~10.0	~15	290	350	200	~10.0	~15	230	280
Hardened die steel (SKD61, DAC, DHA) 42-52HRC	JC8118	~100	~15.0	~25	320	510	~100	~15.0	~25	250	400
		150	~12.0	~15	290	350	150	~12.0	~15	230	280
		200	~10.0	~8	250	200	200	~10.0	~8	200	160
Grey cast iron (FC250) 160-260HB	JC8118	~100	~15.0	~45	800	2,240	~100	~15.0	~45	640	1,790
		150	~12.0	~30	730	1,750	150	~12.0	~30	590	1,420
		200	~10.0	~20	670	1,340	200	~10.0	~20	530	1,060
Nodular cast iron (FCD700) 170-300HB	JC8118	~100	~15.0	~45	480	1,150	~100	~15.0	~45	380	910
		150	~12.0	~30	410	820	150	~12.0	~30	330	660
		200	~10.0	~20	350	560	200	~10.0	~20	280	450
Austenitic stainless steel (SUS304, 316, 317) 17Cr	JC8050	~100	~15.0	~45	380	610	~100	~15.0	~45	310	500
		150	~12.0	~30	350	420	150	~12.0	~30	280	340
		200	~10.0	~20	320	260	200	~10.0	~20	250	200
Ferritic & martensitic stainless steel (SUS403, 420J2, 430) 13Cr	JC8118	~100	~15.0	~45	570	1,370	~100	~15.0	~45	460	1,100
		150	~12.0	~30	510	1,020	150	~12.0	~30	410	820
		200	~10.0	~20	450	720	200	~10.0	~20	360	580

Note

1. Please adjust cutting conditions according to machine rigidity or work rigidity.
2. In case of chatter occurring, recommended to reduce a_p or rpm and keep feed per tooth.
3. a_p should be reduced when using on low rigidity machine.
4. Use air blow.

SIC-EVO**SSV Type**

■ Recommended cutting conditions

● Facemill type - Face milling

Material	Grade	Tool dia.(mm)									
		40					50				
		4N					5N				
		l (mm)	a_p (mm)	a_e (mm)	n (min ⁻¹)	V_f (mm/min)	l (mm)	a_p (mm)	a_e (mm)	n (min ⁻¹)	V_f (mm/min)
Carbon steel (S50C, S55C) below 250HB	JC8050	~100	~3.5	~40	1,190	1,430	~150	~4.0	~50	950	1,430
		150	~2.5	~32	1,030	1,030	200	~3.0	~40	830	1,040
		200	~1.5	~24	880	700	300	~2.0	~30	700	700
Cast steel (GM190, ICD5) below 285HB	JC8050	~100	~3.5	~40	1,190	1,430	~150	~4.0	~50	950	1,430
		150	~2.5	~32	1,030	1,030	200	~3.0	~40	830	1,040
		200	~1.5	~24	880	700	300	~2.0	~30	700	700
Tool & die steel (SKD61, SKD11) below 255HB	JC8050	~100	~3.5	~40	1,190	1,190	~150	~4.0	~50	950	1,190
		150	~2.5	~32	1,030	820	200	~3.0	~40	830	830
		200	~1.5	~24	880	530	300	~2.0	~30	700	530
Mold steel (HPM7, PX5, P20) 30-36 HRC	JC8118	~100	~3.5	~40	1,030	1,030	~150	~4.0	~50	830	1,040
		150	~2.5	~32	950	760	200	~3.0	~40	760	760
		200	~1.5	~24	880	530	300	~2.0	~30	700	530
Mold steel (NAK80, HPM1, P21) 38-43HRC	JC8118	~100	~2.5	~40	880	880	~150	~3.0	~50	700	880
		150	~2.0	~32	800	640	200	~2.5	~40	640	640
		200	~1.5	~24	720	430	300	~1.5	~30	570	430
Hardened die steel (SKD61, DAC, DHA) 42-52HRC	JC8118	~100	~2.0	~32	720	580	~150	~2.5	~40	570	570
		150	~1.5	~24	640	380	200	~2.0	~30	510	380
		200	~1.0	~16	560	220	300	~1.5	~20	450	230
Grey cast iron (FC250) 160-260HB	JC8118	~100	~5.5	~40	1,430	1,720	~150	~6.0	~50	1150	1,730
		150	~3.5	~32	1,190	1,190	200	~4.0	~40	950	1,190
		200	~1.5	~24	1,030	820	300	~2.0	~30	830	830
Nodular cast iron (FCD700) 170-300HB	JC8118	~100	~3.5	~40	1,030	1,030	~150	~4.0	~50	830	1,040
		150	~2.5	~32	950	760	200	~3.0	~40	760	760
		200	~1.5	~24	880	530	300	~2.0	~30	700	530
Austenitic stainless steel (SUS304, 316, 317) 17Cr	JC8050	~100	~3.5	~32	880	700	~150	~4.0	~40	700	700
		150	~2.5	~24	800	480	200	~3.0	~30	640	480
		200	~1.5	~16	720	290	300	~2.0	~20	570	290
Ferritic & martensitic stainless steel (SUS403, 420J2, 430) 13Cr	JC8118	~100	~3.5	~40	1,190	1,190	~150	~4.0	~50	950	1,190
		150	~2.5	~32	1,030	820	200	~3.0	~40	830	830
		200	~1.5	~24	880	530	300	~2.0	~30	700	530

Note

1. Please adjust cutting conditions according to machine rigidity or work rigidity.
2. In case of chatter occurring, recommended to reduce a_p or rpm and keep feed per tooth.
3. a_p should be reduced when using on low rigidity machine.
4. Use air blow.
5. In case of slot milling, apply 50% or less feed (V_f) from standard cutting condition table.

SIC-EVO**SSV Type**

■ Recommended cutting conditions

● Facemill type - Face milling

Material	Grade	Tool dia.(mm)									
		63					80				
		6N					7N				
		ℓ (mm)	a_p (mm)	a_e (mm)	n (min ⁻¹)	V_f (mm/min)	ℓ (mm)	a_p (mm)	a_e (mm)	n (min ⁻¹)	V_f (mm/min)
Carbon steel (S50C, S55C) below 250HB	JC8050	~150	~4.0	~63	760	1,600	~150	~4.0	~80	600	1,470
		200	~3.0	~55	660	1,190	200	~3.0	~65	520	1,090
		300	~2.0	~40	560	840	300	~2.0	~50	440	770
Cast steel (GM190, ICD5) below 285HB	JC8050	~150	~4.0	~63	760	1,600	~150	~4.0	~80	600	1,470
		200	~3.0	~55	660	1,190	200	~3.0	~65	520	1,090
		300	~2.0	~40	560	840	300	~2.0	~50	440	770
Tool & die steel (SKD61, SKD11) below 255HB	JC8050	~150	~4.0	~63	760	1,370	~150	~4.0	~80	600	1,260
		200	~3.0	~55	660	990	200	~3.0	~65	520	910
		300	~2.0	~40	560	670	300	~2.0	~50	440	620
Mold steel (HPM7, PX5, P20) 30-36 HRC	JC8118	~150	~4.0	~63	660	1,190	~150	~4.0	~80	520	1,090
		200	~3.0	~55	610	920	200	~3.0	~65	480	840
		300	~2.0	~40	560	670	300	~2.0	~50	440	620
Mold steel (NAK80, HPM1, P21) 38-43HRC	JC8118	~150	~3.0	~63	560	840	~150	~3.0	~80	440	770
		200	~2.5	~55	510	610	200	~2.5	~65	400	560
		300	~1.5	~40	450	410	300	~1.5	~50	360	380
Hardened die steel (SKD61, DAC, DHA) 42-52HRC	JC8118	~150	~2.5	~55	450	540	~150	~2.5	~65	360	500
		200	~2.0	~40	400	360	200	~2.0	~50	320	340
		300	~1.5	~32	350	210	300	~1.5	~35	280	200
Grey cast iron (FC250) 160-260HB	JC8118	~150	~6.0	~63	910	1,910	~150	~6.0	~80	720	1,760
		200	~4.0	~55	760	1,370	200	~4.0	~65	600	1,260
		300	~2.0	~40	660	990	300	~2.0	~50	520	910
Nodular cast iron (FCD700) 170-300HB	JC8118	~150	~4.0	~63	660	1,190	~150	~4.0	~80	520	1,090
		200	~3.0	~55	610	920	200	~3.0	~65	480	840
		300	~2.0	~40	560	670	300	~2.0	~50	440	620
Austenitic stainless steel (SUS304, 316, 317) 17Cr	JC8050	~150	~4.0	~55	560	670	~150	~4.0	~65	440	620
		200	~3.0	~40	510	460	200	~3.0	~50	400	420
		300	~2.0	~32	450	270	300	~2.0	~35	360	250
Ferritic & martensitic stainless steel (SUS403, 420J2, 430) 13Cr	JC8118	~150	~4.0	~63	760	1,370	~150	~4.0	~80	600	1,260
		200	~3.0	~55	660	990	200	~3.0	~65	520	910
		300	~2.0	~40	560	670	300	~2.0	~50	440	620

Note

1. Please adjust cutting conditions according to machine rigidity or work rigidity.
2. In case of chatter occurring, recommended to reduce a_p or rpm and keep feed per tooth.
3. a_p should be reduced when using on low rigidity machine.
4. Use air blow.
5. In case of slot milling, apply 50% or less feed (V_f) from standard cutting condition table.

SIC-EVO**SSV Type**

■ Recommended cutting conditions

● Facemill type - Face milling

Material	Grade	Tool dia.(mm)									
		100					125				
		8N					8N				
		l (mm)	a_p (mm)	a_e (mm)	n (min ⁻¹)	V_f (mm/min)	l (mm)	a_p (mm)	a_e (mm)	n (min ⁻¹)	V_f (mm/min)
Carbon steel (S50C, S55C) below 250HB	JC8050	~150	~4.0	~100	480	1,340	~150	~4.0	~125	380	1,060
		200	~3.0	~80	410	980	200	~3.0	~100	330	790
		300	~2.0	~60	350	700	300	~2.0	~75	280	560
Cast steel (GM190, ICD5) below 285HB	JC8050	~150	~4.0	~100	480	1,340	~150	~4.0	~125	380	1,060
		200	~3.0	~80	410	980	200	~3.0	~100	330	790
		300	~2.0	~60	350	700	300	~2.0	~75	280	560
Tool & die steel (SKD61, SKD11) below 255HB	JC8050	~150	~4.0	~100	480	1,150	~150	~4.0	~125	380	910
		200	~3.0	~80	410	820	200	~3.0	~100	330	660
		300	~2.0	~60	350	560	300	~2.0	~75	280	450
Mold steel (HPM7, PX5, P20) 30-36 HRC	JC8118	~150	~4.0	~100	410	980	~150	~4.0	~125	330	790
		200	~3.0	~80	380	760	200	~3.0	~100	310	620
		300	~2.0	~60	350	560	300	~2.0	~75	280	450
Mold steel (NAK80, HPM1, P21) 38-43HRC	JC8118	~150	~3.0	~100	350	700	~150	~3.0	~125	280	560
		200	~2.5	~80	320	510	200	~2.5	~100	250	400
		300	~1.5	~60	290	350	300	~1.5	~75	230	280
Hardened die steel (SKD61, DAC, DHA) 42-52HRC	JC8118	~150	~2.5	~80	290	460	~150	~2.5	~100	230	370
		200	~2.0	~60	250	300	200	~2.0	~75	200	240
		300	~1.5	~40	220	180	300	~1.5	~50	180	140
Grey cast iron (FC250) 160-260HB	JC8118	~150	~6.0	~100	570	1,600	~150	~6.0	~125	460	1,290
		200	~4.0	~80	480	1,150	200	~4.0	~100	380	910
		300	~2.0	~60	410	820	300	~2.0	~75	330	660
Nodular cast iron (FCD700) 170-300HB	JC8118	~150	~4.0	~100	410	980	~150	~4.0	~125	330	790
		200	~3.0	~80	380	760	200	~3.0	~100	310	620
		300	~2.0	~60	350	560	300	~2.0	~75	280	450
Austenitic stainless steel (SUS304, 316, 317) 17Cr	JC8050	~150	~4.0	~80	350	560	~150	~4.0	~100	280	450
		200	~3.0	~60	320	380	200	~3.0	~75	250	300
		300	~2.0	~40	290	230	300	~2.0	~50	230	180
Ferritic & martensitic stainless steel (SUS403, 420J2, 430) 13Cr	JC8118	~150	~4.0	~100	480	1,150	~150	~4.0	~125	380	910
		200	~3.0	~80	410	820	200	~3.0	~100	330	660
		300	~2.0	~60	350	560	300	~2.0	~75	280	450

Note

1. Please adjust cutting conditions according to machine rigidity or work rigidity.
2. In case of chatter occurring, recommended to reduce a_p or rpm and keep feed per tooth.
3. a_p should be reduced when using on low rigidity machine.
4. Use air blow.
5. In case of slot milling, apply 50% or less feed (V_f) from standard cutting condition table.

SIC-EVO**SSV Type**

■ Recommended cutting conditions

● Endmill type - Shoulder milling

Material	Grade	Tool dia.(mm)									
		25					30				
		2N					3N				
		ϕ (mm)	a_p (mm)	$a_p \times a_e$ (mm ²)	n (min ⁻¹)	V_f (mm/min)	ϕ (mm)	a_p (mm)	$a_p \times a_e$ (mm ²)	n (min ⁻¹)	V_f (mm/min)
Carbon steel (S50C, S55C) below 250HB	JC8050	60	~10.0	~15	2,550	1,380	70	~12.0	~24	2,120	1,720
		100	~7.0	~10	2,290	1,050	120	~9.0	~18	1,910	1,320
Cast steel (GM190, ICD5) below 285HB	JC8050	60	~10.0	~15	2,290	1,240	70	~12.0	~24	1,910	1,550
		100	~7.0	~10	2,040	940	120	~9.0	~18	1,700	1,170
Tool & die steel (SKD61, SKD11) below 255HB	JC8050	60	~10.0	~15	2,550	1,380	70	~12.0	~24	2,120	1,720
		100	~7.0	~10	2,290	1,050	120	~9.0	~18	1,910	1,320
Mold steel (HPM7, PX5, P20) 30-36 HRC	JC8118	60	~10.0	~15	1,910	1,030	70	~12.0	~24	1,590	1,290
		100	~7.0	~10	1,720	790	120	~9.0	~18	1,430	990
Mold steel (NAK80, HPM1, P21) 38-43HRC	JC8118	60	~10.0	~12	1,530	700	70	~12.0	~18	1,270	880
		100	~7.0	~6	1,340	480	120	~9.0	~13	1,110	600
Hardened die steel (SKD61, DAC, DHA) 42-52HRC	JC8118	60	~10.0	~8	1,270	460	70	~12.0	~12	1,060	570
		100	~7.0	~4	1,150	320	120	~9.0	~8	950	400
Grey cast iron (FC250) 160-260HB	JC8118	60	~10.0	~15	3,180	1,720	70	~12.0	~24	2,650	2,150
		100	~7.0	~10	2,930	1,350	120	~9.0	~18	2,440	1,680
Nodular cast iron (FCD700) 170-300HB	JC8118	60	~10.0	~15	1,910	880	70	~12.0	~24	1,590	1,100
		100	~7.0	~10	1,660	600	120	~9.0	~18	1,380	750
Austenitic stainless steel (SUS304, 316, 317) 17Cr	JC8050	60	~10.0	~15	1,530	550	70	~12.0	~24	1,270	690
		100	~7.0	~10	1,400	390	120	~9.0	~18	1,170	490
Ferritic & martensitic stainless steel (SUS403, 420J2, 430) 13Cr	JC8118	60	~10.0	~15	2,290	1,050	70	~12.0	~24	1,910	1,320
		100	~7.0	~10	2,040	730	120	~9.0	~18	1,700	920

Note

1. Please adjust cutting conditions according to machine rigidity or work rigidity.
2. In case of chatter occurring, recommended to reduce a_p or rpm and keep feed per tooth.
3. a_p should be reduced when using on low rigidity machine.
4. Use air blow.

SIC-EVO**SSV Type**

■ Recommended cutting conditions

● Endmill type - Shoulder milling

Material	Grade	Tool dia.(mm)									
		32					40				
		3N					4N				
		ℓ (mm)	a_p (mm)	$a_p \times a_e$ (mm ²)	n (min ⁻¹)	V_f (mm/min)	ℓ (mm)	a_p (mm)	$a_p \times a_e$ (mm ²)	n (min ⁻¹)	V_f (mm/min)
Carbon steel (S50C, S55C) below 250HB	JC8050	70	~12.0	~24	1,990	1,610	50	~15.0	~30	1,590	1,720
		120	~9.0	~18	1,790	1,240	100	~10.0	~20	1,430	1,320
Cast steel (GM190, ICD5) below 285HB	JC8050	70	~12.0	~24	1,790	1,450	50	~15.0	~30	1,430	1,540
		120	~9.0	~18	1,590	1,100	100	~10.0	~20	1,270	1,170
Tool & die steel (SKD61, SKD11) below 255HB	JC8050	70	~12.0	~24	1,990	1,610	50	~15.0	~30	1,590	1,720
		120	~9.0	~18	1,790	1,240	100	~10.0	~20	1,430	1,320
Mold steel (HPM7, PX5, P20) 30-36 HRC	JC8118	70	~12.0	~24	1,490	1,210	50	~15.0	~30	1,190	1,290
		120	~9.0	~18	1,340	920	100	~10.0	~20	1,070	980
Mold steel (NAK80, HPM1, P21) 38-43HRC	JC8118	70	~12.0	~18	1,190	820	50	~15.0	~20	950	870
		120	~9.0	~13	1,040	560	100	~10.0	~15	840	600
Hardened die steel (SKD61, DAC, DHA) 42-52HRC	JC8118	70	~12.0	~12	990	530	50	~12.0	~12	800	580
		120	~9.0	~8	900	380	100	~10.0	~8	720	400
Grey cast iron (FC250) 160-260HB	JC8118	70	~12.0	~24	2,490	2,020	50	~15.0	~30	1,990	2,150
		120	~9.0	~18	2,290	1,580	100	~10.0	~20	1,830	1,680
Nodular cast iron (FCD700) 170-300HB	JC8118	70	~12.0	~24	1,490	1,030	50	~15.0	~30	1,190	1,090
		120	~9.0	~18	1,290	700	100	~10.0	~20	1,030	740
Austenitic stainless steel (SUS304, 316, 317) 17Cr	JC8050	70	~12.0	~24	1,190	640	50	~15.0	~30	950	680
		120	~9.0	~18	1,090	460	100	~10.0	~20	880	490
Ferritic & martensitic stainless steel (SUS403, 420J2, 430) 13Cr	JC8118	70	~12.0	~24	1,790	1,240	50	~15.0	~30	1,430	1,320
		120	~9.0	~18	1,590	860	100	~10.0	~20	1,270	910

Note

1. Please adjust cutting conditions according to machine rigidity or work rigidity.
2. In case of chatter occurring, recommended to reduce a_p or rpm and keep feed per tooth.
3. a_p should be reduced when using on low rigidity machine.
4. Use air blow.

SIC-EVO**SSV Type**

■ Recommended cutting conditions

● Endmill type - Shoulder milling

Material	Grade	Tool dia.(mm)				
		50				
		5N				
		ℓ (mm)	a_p (mm)	$a_p \times a_e$ (mm ²)	n (min ⁻¹)	V_f (mm/min)
Carbon steel (S50C, S55C) below 250HB	JC8050	40	~15.0	~40	1,270	1,710
Cast steel (GM190, ICD5) below 285HB	JC8050	40	~15.0	~40	1,150	1,550
Tool & die steel (SKD61, SKD11) below 255HB	JC8050	40	~15.0	~40	1,270	1,710
Mold steel (HPM7, PX5, P20) 30-36 HRC	JC8118	40	~15.0	~40	950	1,280
Mold steel (NAK80, HPM1, P21) 38-43HRC	JC8118	40	~15.0	~30	760	870
Hardened die steel (SKD61, DAC, DHA) 42-52HRC	JC8118	40	~15.0	~18	640	580
Grey cast iron (FC250) 160-260HB	JC8118	40	~15.0	~40	1,590	2,150
Nodular cast iron (FCD700) 170-300HB	JC8118	40	~15.0	~40	950	1,090
Austenitic stainless steel (SUS304, 316, 317) 17Cr	JC8050	40	~15.0	~40	760	680
Ferritic & martensitic stainless steel (SUS403, 420J2, 430) 13Cr	JC8118	40	~15.0	~40	1,150	1,320

Note

1. Please adjust cutting conditions according to machine rigidity or work rigidity.
2. In case of chatter occurring, recommended to reduce a_p or rpm and keep feed per tooth.
3. a_p should be reduced when using on low rigidity machine.
4. Use air blow.

SIC-EVO**SSV Type**

■ Recommended cutting conditions

● Endmill type - Face milling

Material	Grade	Tool dia.(mm)									
		25					30				
		2N					3N				
		l (mm)	a_p (mm)	a_e (mm)	n (min ⁻¹)	V_f (mm/min)	l (mm)	a_p (mm)	a_e (mm)	n (min ⁻¹)	V_f (mm/min)
Carbon steel (S50C, S55C) below 250HB	JC8050	~60	~3.0	~25	1,910	1,030	~70	~3.5	~30	1,590	1,290
		100	~2.0	~20	1,660	760	120	~2.5	~24	1,380	950
Cast steel (GM190, JCD5) below 285HB	JC8050	~60	~3.0	~25	1,910	1,030	~70	~3.5	~30	1,590	1,290
		100	~2.0	~20	1,660	760	120	~2.5	~24	1,380	950
Tool & die steel (SKD61, SKD11) below 255HB	JC8050	~60	~3.0	~25	1,910	880	~70	~3.5	~30	1,590	1,100
		100	~2.0	~20	1,660	600	120	~2.5	~24	1,380	750
Mold steel (HPM7, PX5, P20) 30-36 HRC	JC8118	~60	~3.0	~25	1,660	760	~70	~3.5	~30	1,380	950
		100	~2.0	~20	1,530	550	120	~2.5	~24	1,270	690
Mold steel (NAK80, HPM1, P21) 38-43HRC	JC8118	~60	~2.0	~25	1,400	640	~70	~2.5	~30	1,170	810
		100	~1.5	~20	1,270	460	120	~2.0	~24	1,060	570
Hardened die steel (SKD61, DAC, DHA) 42-52HRC	JC8118	~60	~1.5	~20	1,150	410	~70	~2.0	~24	950	510
		100	~1.0	~15	1,020	290	120	~1.5	~18	850	360
Grey cast iron (FC250) 160-260HB	JC8118	~60	~5.0	~25	2,550	1,380	~70	~5.5	~30	2,120	1,720
		100	~3.0	~20	2,290	1,050	120	~3.5	~24	1,910	1,320
Nodular cast iron (FCD700) 170-300HB	JC8118	~60	~3.0	~25	1,660	760	~70	~3.5	~30	1,380	950
		100	~2.0	~20	1,530	550	120	~2.5	~24	1,270	690
Austenitic stainless steel (SUS304, 316, 317) 17Cr	JC8050	~60	~3.0	~20	1,400	500	~70	~3.5	~24	1,170	630
		100	~2.0	~15	1,270	360	120	~2.5	~18	1,060	450
Ferritic & martensitic stainless steel (SUS403, 420J2, 430) 13Cr	JC8118	~60	~3.0	~25	1,910	880	~70	~3.5	~30	1,590	1,100
		100	~2.0	~20	1,660	600	120	~2.5	~24	1,380	750

Note

1. Please adjust cutting conditions according to machine rigidity or work rigidity.
2. In case of chatter occurring, recommended to reduce a_p or rpm and keep feed per tooth.
3. a_p should be reduced when using on low rigidity machine.
4. Use air blow.
5. In case of slot milling, apply 50% or less feed (V_f) from standard cutting condition table.

SIC-EVO**SSV Type**

■ Recommended cutting conditions

● Endmill type - Face milling

Material	Grade	Tool dia.(mm)									
		32					40				
		3N					4N				
		l (mm)	a_p (mm)	a_e (mm)	n (min ⁻¹)	V_f (mm/min)	l (mm)	a_p (mm)	a_e (mm)	n (min ⁻¹)	V_f (mm/min)
Carbon steel (S50C, S55C) below 250HB	JC8050	~70	~3.5	~32	1,490	1,210	~50	~3.5	~40	1,190	1,290
		120	~2.5	~26	1,290	890	100	~2.5	~32	1,030	950
Cast steel (GM190, ICD5) below 285HB	JC8050	~70	~3.5	~32	1,490	1,210	~50	~3.5	~40	1,190	1,290
		120	~2.5	~26	1,290	890	100	~2.5	~32	1,030	950
Tool & die steel (SKD61, SKD11) below 255HB	JC8050	~70	~3.5	~32	1,490	1,030	~50	~3.5	~40	1,190	1,090
		120	~2.5	~26	1,290	700	100	~2.5	~32	1,030	740
Mold steel (HPM7, PX5, P20) 30-36 HRC	JC8118	~70	~3.5	~32	1,290	890	~50	~3.5	~40	1,030	950
		120	~2.5	~26	1,190	640	100	~2.5	~32	950	680
Mold steel (NAK80, HPM1, P21) 38-43HRC	JC8118	~70	~2.5	~32	1,090	750	~50	~2.5	~40	880	810
		120	~2.0	~26	990	530	100	~2.0	~32	800	580
Hardened die steel (SKD61, DAC, DHA) 42-52HRC	JC8118	~70	~2.0	~26	900	490	~50	~2.0	~32	720	520
		120	~1.5	~19	800	340	100	~1.5	~24	640	360
Grey cast iron (FC250) 160-260HB	JC8118	~70	~5.5	~32	1,990	1,610	~50	~5.5	~40	1,590	1,720
		120	~3.5	~26	1,790	1,240	100	~3.5	~32	1,430	1,320
Nodular cast iron (FCD700) 170-300HB	JC8118	~70	~3.5	~32	1,290	890	~50	~3.5	~40	1,030	950
		120	~2.5	~26	1,190	640	100	~2.5	~32	950	680
Austenitic stainless steel (SUS304, 316, 317) 17Cr	JC8050	~70	~3.5	~26	1,090	590	~50	~3.5	~32	880	630
		120	~2.5	~19	990	420	100	~2.5	~24	800	450
Ferritic & martensitic stainless steel (SUS403, 420J2, 430) 13Cr	JC8118	~70	~3.5	~32	1,490	1,030	~50	~3.5	~40	1,190	1,090
		120	~2.5	~26	1,290	700	100	~2.5	~32	1,030	740

Note

1. Please adjust cutting conditions according to machine rigidity or work rigidity.
2. In case of chatter occurring, recommended to reduce a_p or rpm and keep feed per tooth.
3. a_p should be reduced when using on low rigidity machine.
4. Use air blow.
5. In case of slot milling, apply 50% or less feed (V_f) from standard cutting condition table.

SIC-EVO**SSV Type**

■ Recommended cutting conditions

● Endmill type - Face milling

Material	Grade	Tool dia.(mm)				
		50				
		5N				
		l (mm)	a_p (mm)	a_e (mm)	n (min ⁻¹)	V_f (mm/min)
Carbon steel (S50C, S55C) below 250HB	JC8050	40	~4.0	~50	950	1,280
Cast steel (GM190, ICD5) below 285HB	JC8050	40	~4.0	~50	950	1,280
Tool & die steel (SKD61, SKD11) below 255HB	JC8050	40	~4.0	~50	950	1,090
Mold steel (HPM7, PX5, P20) 30-36 HRC	JC8118	40	~4.0	~50	830	950
Mold steel (NAK80, HPM1, P21) 38-43HRC	JC8118	40	~3.0	~50	700	810
Hardened die steel (SKD61, DAC, DHA) 42-52HRC	JC8118	40	~2.5	~40	570	510
Grey cast iron (FC250) 160-260HB	JC8118	40	~6.0	~50	1,270	1,710
Nodular cast iron (FCD700) 170-300HB	JC8118	40	~4.0	~50	830	950
Austenitic stainless steel (SUS304, 316, 317) 17Cr	JC8050	40	~4.0	~40	700	630
Ferritic & martensitic stainless steel (SUS403, 420J2, 430) 13Cr	JC8118	40	~4.0	~50	950	1,090

Note

1. Please adjust cutting conditions according to machine rigidity or work rigidity.
2. In case of chatter occurring, recommended to reduce a_p or rpm and keep feed per tooth.
3. a_p should be reduced when using on low rigidity machine.
4. Use air blow.
5. In case of slot milling , apply 50% or less feed (V_f) from standard cutting condition table.

SIC-EVO**SSV Type**

■ Recommended cutting conditions

● Modular head type + MSN carbide shank - Shoulder milling

Material	Grade	Tool dia.(mm)									
		25					28				
		2N					2N				
		l (mm)	a_p (mm)	$a_p \times a_e$ (mm ²)	n (min ⁻¹)	V_f (mm/min)	l (mm)	a_p (mm)	$a_p \times a_e$ (mm ²)	n (min ⁻¹)	V_f (mm/min)
Carbon steel (S50C, S55C) below 250HB	JC8050	~90	~10.0	~15	2,550	1,530	~90	~10.0	~15	2,270	1,360
		140	~7.0	~10	2,290	1,150	140	~7.0	~10	2,050	1,030
		210	~4.0	~5	2,040	820	210	~4.0	~5	1,820	730
Cast steel (GM190, ICD5) below 285HB	JC8050	~90	~10.0	~15	2,290	1,370	~90	~10.0	~15	2,050	1,230
		140	~7.0	~10	2,040	1,020	140	~7.0	~10	1,820	910
		210	~4.0	~5	1,780	710	210	~4.0	~5	1,590	640
Tool & die steel (SKD61, SKD11) below 255HB	JC8050	~90	~10.0	~15	2,550	1,530	~90	~10.0	~15	2,270	1,360
		140	~7.0	~10	2,290	1,150	140	~7.0	~10	2,050	1,030
		210	~4.0	~5	2,040	820	210	~4.0	~5	1,820	730
Mold steel (HPM7, PX5, P20) 30-36 HRC	JC8118	~90	~10.0	~15	1,910	1,150	~90	~10.0	~15	1,710	1,030
		140	~7.0	~10	1,720	860	140	~7.0	~10	1,530	770
		210	~4.0	~5	1,530	610	210	~4.0	~5	1,360	540
Mold steel (NAK80, HPM1, P21) 38-43HRC	JC8118	~90	~10.0	~12	1,530	770	~90	~10.0	~12	1,360	680
		140	~7.0	~6	1,340	540	140	~7.0	~6	1,190	480
		210	~4.0	~2	1,150	350	210	~4.0	~2	1,020	310
Hardened die steel (SKD61, DAC, DHA) 42-52HRC	JC8118	~90	~10.0	~8	1,270	510	~90	~10.0	~8	1,140	460
		140	~7.0	~4	1,150	350	140	~7.0	~4	1,020	310
		210	~4.0	~2	1,020	200	210	~4.0	~2	910	180
Grey cast iron (FC250) 160-260HB	JC8118	~90	~10.0	~15	3,180	1,910	~90	~10.0	~15	2,840	1,700
		140	~7.0	~10	2,930	1,470	140	~7.0	~10	2,610	1,310
		210	~4.0	~5	2,670	1,070	210	~4.0	~5	2,390	960
Nodular cast iron (FCD700) 170-300HB	JC8118	~90	~10.0	~15	1,910	960	~90	~10.0	~15	1,710	860
		140	~7.0	~10	1,660	660	140	~7.0	~10	1,480	590
		210	~4.0	~5	1,400	420	210	~4.0	~5	1,250	380
Austenitic stainless steel (SUS304, 316, 317) 17Cr	JC8050	~90	~10.0	~15	1,530	610	~90	~10.0	~15	1,360	540
		140	~7.0	~10	1,400	420	140	~7.0	~10	1,250	380
		210	~4.0	~5	1,270	250	210	~4.0	~5	1,140	230
Ferritic & martensitic stainless steel (SUS403, 420J2, 430) 13Cr	JC8118	~90	~10.0	~15	2,290	1,150	~90	~10.0	~15	2,050	1,030
		140	~7.0	~10	2,040	820	140	~7.0	~10	1,820	730
		210	~4.0	~5	1,780	530	210	~4.0	~5	1,590	480

Note

1. Please adjust cutting conditions according to machine rigidity or work rigidity.
2. In case of chatter occurring, recommended to reduce a_p or rpm and keep feed per tooth.
3. a_p should be reduced when using on low rigidity machine.
4. Use air blow.

SIC-EVO**SSV Type**

■ Recommended cutting conditions

● Modular head type + MSN carbide shank - Shoulder milling

Material	Grade	Tool dia.(mm)									
		30					32				
		3N					3N				
		ℓ (mm)	a_p (mm)	$a_p \times a_e$ (mm ²)	n (min ⁻¹)	V_f (mm/min)	ℓ (mm)	a_p (mm)	$a_p \times a_e$ (mm ²)	n (min ⁻¹)	V_f (mm/min)
Carbon steel (S50C, S55C) below 250HB	JC8050	~100	~12.0	~24	2,120	1,910	~100	~12.0	~24	1,990	1,790
		150	~9.0	~18	1,910	1,430	150	~9.0	~18	1,790	1,340
		210	~6.0	~9	1,700	1,020	210	~6.0	~9	1,590	950
Cast steel (GM190, ICD5) below 285HB	JC8050	~100	~12.0	~24	1,910	1,720	~100	~12.0	~24	1,790	1,610
		150	~9.0	~18	1,700	1,280	150	~9.0	~18	1,590	1,190
		210	~6.0	~9	1,490	890	210	~6.0	~9	1,390	830
Tool & die steel (SKD61, SKD11) below 255HB	JC8050	~100	~12.0	~24	2,120	1,910	~100	~12.0	~24	1,990	1,790
		150	~9.0	~18	1,910	1,430	150	~9.0	~18	1,790	1,340
		210	~6.0	~9	1,700	1,020	210	~6.0	~9	1,590	950
Mold steel (HPM7, PX5, P20) 30-36 HRC	JC8118	~100	~12.0	~24	1,590	1,430	~100	~12.0	~24	1,490	1,340
		150	~9.0	~18	1,430	1,070	150	~9.0	~18	1,340	1,010
		210	~6.0	~9	1,270	760	210	~6.0	~9	1,190	710
Mold steel (NAK80, HPM1, P21) 38-43HRC	JC8118	~100	~12.0	~18	1,270	950	~100	~12.0	~18	1,190	890
		150	~9.0	~13	1,110	670	150	~9.0	~13	1,040	620
		210	~6.0	~7	950	430	210	~6.0	~7	900	410
Hardened die steel (SKD61, DAC, DHA) 42-52HRC	JC8118	~100	~12.0	~12	1,060	640	~100	~12.0	~12	990	590
		150	~9.0	~8	950	430	150	~9.0	~8	900	410
		210	~6.0	~3	850	260	210	~6.0	~3	800	240
Grey cast iron (FC250) 160-260HB	JC8118	~100	~12.0	~24	2,650	2,390	~100	~12.0	~24	2,490	2,240
		150	~9.0	~18	2,440	1,830	150	~9.0	~18	2,290	1,720
		210	~6.0	~12	2,230	1,340	210	~6.0	~12	2,090	1,250
Nodular cast iron (FCD700) 170-300HB	JC8118	~100	~12.0	~24	1,590	1,190	~100	~12.0	~24	1,490	1,120
		150	~9.0	~18	1,380	830	150	~9.0	~18	1,290	770
		210	~6.0	~9	1,170	530	210	~6.0	~9	1,090	490
Austenitic stainless steel (SUS304, 316, 317) 17Cr	JC8050	~100	~12.0	~24	1,270	760	~100	~12.0	~24	1,190	710
		150	~9.0	~18	1,170	530	150	~9.0	~18	1,090	490
		210	~6.0	~9	1,060	320	210	~6.0	~9	990	300
Ferritic & martensitic stainless steel (SUS403, 420J2, 430) 13Cr	JC8118	~100	~12.0	~24	1,910	1,430	~100	~12.0	~24	1,790	1,340
		150	~9.0	~18	1,700	1,020	150	~9.0	~18	1,590	950
		210	~6.0	~9	1,490	670	210	~6.0	~9	1,390	630

Note

1. Please adjust cutting conditions according to machine rigidity or work rigidity.
2. In case of chatter occurring, recommended to reduce a_p or rpm and keep feed per tooth.
3. a_p should be reduced when using on low rigidity machine.
4. Use air blow.

SIC-EVO

SSV Type

■ Recommended cutting conditions

● Modular head type + MSN carbide shank - Shoulder milling

Material	Grade	Tool dia.(mm)									
		35					40				
		3N					4N				
		ℓ (mm)	ap (mm)	ap×ae (mm ²)	n (min ⁻¹)	Vf (mm/min)	ℓ (mm)	ap (mm)	ap×ae (mm ²)	n (min ⁻¹)	Vf (mm/min)
Carbon steel (S50C, S55C) below 250HB	JC8050	~100	~12.0	~24	1,820	1,640	~100	~15.0	~30	1,590	1,910
		150	~9.0	~18	1,640	1,230	150	~10.0	~20	1,430	1,430
		210	~6.0	~9	1,460	880	210	~8.0	~12	1,270	1,020
Cast steel (GM190, ICD5) below 285HB	JC8050	~100	~12.0	~24	1,640	1,480	~100	~15.0	~30	1,430	1,720
		150	~9.0	~18	1,460	1,100	150	~10.0	~20	1,270	1,270
		210	~6.0	~9	1,270	760	210	~8.0	~12	1,110	890
Tool & die steel (SKD61, SKD11) below 255HB	JC8050	~100	~12.0	~24	1,820	1,640	~100	~15.0	~30	1,590	1,910
		150	~9.0	~18	1,640	1,230	150	~10.0	~20	1,430	1,430
		210	~6.0	~9	1,460	880	210	~8.0	~12	1,270	1,020
Mold steel (HPM7, PX5, P20) 30-36 HRC	JC8118	~100	~12.0	~24	1,360	1,220	~100	~15.0	~30	1,190	1,430
		150	~9.0	~18	1,230	920	150	~10.0	~20	1,070	1,070
		210	~6.0	~9	1,090	650	210	~8.0	~12	950	760
Mold steel (NAK80, HPM1, P21) 38-43HRC	JC8118	~100	~12.0	~18	1,090	820	~100	~15.0	~20	950	950
		150	~9.0	~13	950	570	150	~10.0	~15	840	670
		210	~6.0	~7	820	370	210	~8.0	~8	720	430
Hardened die steel (SKD61, DAC, DHA) 42-52HRC	JC8118	~100	~12.0	~12	910	550	~100	~12.0	~12	800	640
		150	~9.0	~8	820	370	150	~10.0	~8	720	430
		210	~6.0	~3	730	220	210	~8.0	~3	640	260
Grey cast iron (FC250) 160-260HB	JC8118	~100	~12.0	~24	2,270	2,040	~100	~15.0	~30	1,990	2,390
		150	~9.0	~18	2,090	1,570	150	~10.0	~20	1,830	1,830
		210	~6.0	~12	1,910	1,150	210	~8.0	~12	1,670	1,340
Nodular cast iron (FCD700) 170-300HB	JC8118	~100	~12.0	~24	1,360	1,020	~100	~15.0	~30	1,190	1,190
		150	~9.0	~18	1,180	710	150	~10.0	~20	1,030	820
		210	~6.0	~9	1,000	450	210	~8.0	~12	880	530
Austenitic stainless steel (SUS304, 316, 317) 17Cr	JC8050	~100	~12.0	~24	1,090	650	~100	~15.0	~30	950	760
		150	~9.0	~18	1,000	450	150	~10.0	~20	880	530
		210	~6.0	~9	910	270	210	~8.0	~12	800	320
Ferritic & martensitic stainless steel (SUS403, 420J2, 430) 13Cr	JC8118	~100	~12.0	~24	1,640	1,230	~100	~15.0	~30	1,430	1,430
		150	~9.0	~18	1,460	880	150	~10.0	~20	1,270	1,020
		210	~6.0	~9	1,270	570	210	~8.0	~12	1,110	670

Note

1. Please adjust cutting conditions according to machine rigidity or work rigidity.
2. In case of chatter occurring, recommended to reduce ap or rpm and keep feed per tooth.
3. ap should be reduced when using on low rigidity machine.
4. Use air blow.

SIC-EVO**SSV Type**

■ Recommended cutting conditions

● Modular head type + MSN carbide shank - Face milling

Material	Grade	Tool dia.(mm)									
		25					28				
		2N					2N				
		ℓ (mm)	a _p (mm)	a _e (mm)	n (min ⁻¹)	V _f (mm/min)	ℓ (mm)	a _p (mm)	a _e (mm)	n (min ⁻¹)	V _f (mm/min)
Carbon steel (S50C, S55C) below 250HB	JC8050	~90	~3.0	~25	1,910	1,150	~90	~3.0	~28	1,710	1,030
		140	~2.0	~20	1,660	830	140	~2.0	~22	1,480	740
		210	~1.0	~15	1,400	560	210	~1.0	~17	1,250	500
Cast steel (GM190, ICD5) below 285HB	JC8050	~90	~3.0	~25	1,910	1,150	~90	~3.0	~28	1,710	1,030
		140	~2.0	~20	1,660	830	140	~2.0	~22	1,480	740
		210	~1.0	~15	1,400	560	210	~1.0	~17	1,250	500
Tool & die steel (SKD61, SKD11) below 255HB	JC8050	~90	~3.0	~25	1,910	960	~90	~3.0	~28	1,710	860
		140	~2.0	~20	1,660	660	140	~2.0	~22	1,480	590
		210	~1.0	~15	1,400	420	210	~1.0	~17	1,250	380
Mold steel (HPM7, PX5, P20) 30-36 HRC	JC8118	~90	~3.0	~25	1,660	830	~90	~3.0	~28	1,480	740
		140	~2.0	~20	1,530	610	140	~2.0	~22	1,360	540
		210	~1.0	~15	1,400	420	210	~1.0	~17	1,250	380
Mold steel (NAK80, HPM1, P21) 38-43HRC	JC8118	~90	~2.0	~25	1,400	700	~90	~2.0	~28	1,250	630
		140	~1.5	~20	1,270	510	140	~1.5	~22	1,140	460
		210	~1.0	~15	1,150	350	210	~1.0	~17	1,020	310
Hardened die steel (SKD61, DAC, DHA) 42-52HRC	JC8118	~90	~1.5	~20	1,150	460	~90	~1.5	~22	1,020	410
		140	~1.0	~15	1,020	310	140	~1.0	~17	910	270
		210	~0.5	~10	890	180	210	~0.5	~11	800	160
Grey cast iron (FC250) 160-260HB	JC8118	~90	~5.0	~25	2,550	1,530	~90	~5.0	~28	2,270	1,360
		140	~3.0	~20	2,290	1,150	140	~3.0	~22	2,050	1,030
		210	~1.0	~15	2,040	820	210	~1.0	~17	1,820	730
Nodular cast iron (FCD700) 170-300HB	JC8118	~90	~3.0	~25	1,660	830	~90	~3.0	~28	1,480	740
		140	~2.0	~20	1,530	610	140	~2.0	~22	1,360	540
		210	~1.0	~15	1,400	420	210	~1.0	~17	1,250	380
Austenitic stainless steel (SUS304, 316, 317) 17Cr	JC8050	~90	~3.0	~20	1,400	560	~90	~3.0	~22	1,250	500
		140	~2.0	~15	1,270	380	140	~2.0	~17	1,140	340
		210	~1.0	~10	1,150	230	210	~1.0	~11	1,020	200
Ferritic & martensitic stainless steel (SUS403, 420J2, 430) 13Cr	JC8118	~90	~3.0	~25	1,910	960	~90	~3.0	~28	1,710	860
		140	~2.0	~20	1,660	660	140	~2.0	~22	1,480	590
		210	~1.0	~15	1,400	420	210	~1.0	~17	1,250	380

Note

1. Please adjust cutting conditions according to machine rigidity or work rigidity.
2. In case of chatter occurring, recommended to reduce a_p or rpm and keep feed per tooth.
3. a_p should be reduced when using on low rigidity machine.
4. Use air blow.

In case of slot milling , apply 50% or less feed (V_f) from standard cutting condition table.

SIC-EVO**SSV Type**

■ Recommended cutting conditions

● Modular head type + MSN carbide shank - Face milling

Material	Grade	Tool dia.(mm)									
		30					32				
		3N					3N				
		ℓ (mm)	a _p (mm)	a _e (mm)	n (min ⁻¹)	V _f (mm/min)	ℓ (mm)	a _p (mm)	a _e (mm)	n (min ⁻¹)	V _f (mm/min)
Carbon steel (S50C, S55C) below 250HB	JC8050	~100	~3.5	~30	1,590	1,430	~100	~3.5	~32	1,490	1,340
		150	~2.5	~24	1,380	1,040	150	~2.5	~26	1,290	970
		210	~1.5	~18	1,170	700	210	~1.5	~19	1,090	650
Cast steel (GM190, ICD5) below 285HB	JC8050	~100	~3.5	~30	1,590	1,430	~100	~3.5	~32	1,490	1,340
		150	~2.5	~24	1,380	1,040	150	~2.5	~26	1,290	970
		210	~1.5	~18	1,170	700	210	~1.5	19	1,090	650
Tool & die steel (SKD61, SKD11) below 255HB	JC8050	~100	~3.5	~30	1,590	1,190	~100	~3.5	~32	1,490	1,120
		150	~2.5	~24	1,380	830	150	~2.5	~26	1,290	770
		210	~1.5	~18	1,170	530	210	~1.5	~19	1,090	490
Mold steel (HPM7, PX5, P20) 30-36 HRC	JC8118	~100	~3.5	~30	1,380	1,040	~100	~3.5	~32	1,290	970
		150	~2.5	~24	1,270	760	150	~2.5	~26	1,190	710
		210	~1.5	~18	1,170	530	210	~1.5	~19	1,090	490
Mold steel (NAK80, HPM1, P21) 38-43HRC	JC8118	~100	~2.5	~30	1,170	880	~100	~2.5	~32	1,090	820
		150	~2.0	~24	1,060	640	150	~2.0	~26	990	590
		210	~1.5	~18	950	430	210	~1.5	~19	900	410
Hardened die steel (SKD61, DAC, DHA) 42-52HRC	JC8118	~100	~2.0	~24	950	570	~100	~2.0	~26	900	540
		150	~1.5	~18	850	380	150	~1.5	~19	800	360
		210	~1.0	~12	740	220	210	~1.0	~13	700	210
Grey cast iron (FC250) 160-260HB	JC8118	~100	~5.5	~30	2,120	1,910	~100	~5.5	~32	1,990	1,790
		150	~3.5	~24	1,910	1,430	150	~3.5	~26	1,790	1,340
		210	~1.5	~18	1,700	1,020	210	~1.5	~19	1,590	950
Nodular cast iron (FCD700) 170-300HB	JC8118	~100	~3.5	~30	1,380	1,040	~100	~3.5	~32	1,290	970
		150	~2.5	~24	1,270	760	150	~2.5	~26	1,190	710
		210	~1.5	~18	1,170	530	210	~1.5	~19	1,090	490
Austenitic stainless steel (SUS304, 316, 317) 17Cr	JC8050	~100	~3.5	~24	1,170	700	~100	~3.5	~26	1,090	650
		150	~2.5	~18	1,060	480	150	~2.5	~19	990	450
		210	~1.5	~12	950	290	210	~1.5	~13	900	270
Ferritic & martensitic stainless steel (SUS403, 420J2, 430) 13Cr	JC8118	~100	~3.5	~30	1,590	1,190	~100	~3.5	~32	1,490	1,120
		150	~2.5	~24	1,380	830	150	~2.5	~26	1,290	770
		210	~1.5	~18	1,170	530	210	~1.5	~19	1,090	490

Note

1. Please adjust cutting conditions according to machine rigidity or work rigidity.
2. In case of chatter occurring, recommended to reduce a_p or rpm and keep feed per tooth.
3. a_p should be reduced when using on low rigidity machine.
4. Use air blow.

In case of slot milling , apply 50% or less feed (V_f) from standard cutting condition table.

SIC-EVO**SSV Type**

■ Recommended cutting conditions

● Modular head type + MSN carbide shank - Face milling

Material	Grade	Tool dia.(mm)									
		35					40				
		3N					4N				
		ℓ (mm)	a _p (mm)	a _e (mm)	n (min ⁻¹)	V _f (mm/min)	ℓ (mm)	a _p (mm)	a _e (mm)	n (min ⁻¹)	V _f (mm/min)
Carbon steel (S50C, S55C) below 250HB	JC8050	~100	~3.5	~35	1,360	1,220	~100	~3.5	~40	1,190	1,430
		150	~2.5	~28	1,180	890	150	~2.5	~32	1,030	1,030
		210	~1.5	~21	1,000	600	210	~1.5	~24	880	700
Cast steel (GM190, ICD5) below 285HB	JC8050	~100	~3.5	~35	1,360	1,220	~100	~3.5	~40	1,190	1,430
		150	~2.5	~28	1,180	890	150	~2.5	~32	1,030	1,030
		210	~1.5	~21	1,000	600	210	~1.5	~24	880	700
Tool & die steel (SKD61, SKD11) below 255HB	JC8050	~100	~3.5	~35	1,360	1,020	~100	~3.5	~40	1,190	1,190
		150	~2.5	~28	1,180	710	150	~2.5	~32	1,030	820
		210	~1.5	~21	1,000	450	210	~1.5	~24	880	530
Mold steel (HPM7, PX5, P20) 30-36 HRC	JC8118	~100	~3.5	~35	1,180	890	~100	~3.5	~40	1,030	1,030
		150	~2.5	~28	1,090	650	150	~2.5	~32	950	760
		210	~1.5	~21	1,000	450	210	~1.5	~24	880	530
Mold steel (NAK80, HPM1, P21) 38-43HRC	JC8118	~100	~2.5	~35	1,000	750	~100	~2.5	~40	880	880
		150	~2.0	~28	910	550	150	~2.0	~32	800	640
		210	~1.5	~21	820	370	210	~1.5	~24	720	430
Hardened die steel (SKD61, DAC, DHA) 42-52HRC	JC8118	~100	~2.0	~28	820	490	~100	~2.0	~32	720	580
		150	~1.5	~21	730	330	150	~1.5	~24	640	380
		210	~1.0	~14	640	190	210	~1.0	~16	560	220
Grey cast iron (FC250) 160-260HB	JC8118	~100	~5.5	~35	1,820	1,640	~100	~5.5	~40	1,590	1,910
		150	~3.5	~28	1,640	1,230	150	~3.5	~32	1,430	1,430
		210	~1.5	~21	1,460	880	210	~1.5	~24	1,270	1,020
Nodular cast iron (FCD700) 170-300HB	JC8118	~100	~3.5	~35	1,180	890	~100	~3.5	~40	1,030	1,030
		150	~2.5	~28	1,090	650	150	~2.5	~32	950	760
		210	~1.5	~21	1,000	450	210	~1.5	~24	880	530
Austenitic stainless steel (SUS304, 316, 317) 17Cr	JC8050	~100	~3.5	~28	1,000	600	~100	~3.5	~32	880	700
		150	~2.5	~21	910	410	150	~2.5	~24	800	480
		210	~1.5	~14	820	250	210	~1.5	~16	720	290
Ferritic & martensitic stainless steel (SUS403, 420J2, 430) 13Cr	JC8118	~100	~3.5	~35	1,360	1,020	~100	~3.5	~40	1,190	1,190
		150	~2.5	~28	1,180	710	150	~2.5	~32	1,030	820
		210	~1.5	~21	1,000	450	210	~1.5	~24	880	530

Note

1. Please adjust cutting conditions according to machine rigidity or work rigidity.
2. In case of chatter occurring, recommended to reduce a_p or rpm and keep feed per tooth.
3. a_p should be reduced when using on low rigidity machine.
4. Use air blow.

In case of slot milling , apply 50% or less feed (V_f) from standard cutting condition table.